



Thank you for purchasing a Honda Outboard Motor.

This manual covers operation and maintenance of the Honda BF40D/50D Outboard Motor. All information in this publication is based on the latest product information available at the time of approval for printing. Honda Motor Co., Ltd. reserves the right to make changes at any time without notice and without incurring any obligation.

No part of this publication may be reproduced without written permission.

This manual should be considered a permanent part of the Outboard Motor and should remain with it if it is resold.

Throughout this manual, you will see safety messages preceded by the following words and symbols. Here's what they mean:

**▲ DANGER**

**Indicates serious injury or death WILL result if instructions are not followed.**

**▲ WARNING**

**Indicates a strong possibility that serious personal injury or death may result if instructions are not followed.**

**▲ CAUTION**

**Indicates a possibility that personal injury or equipment damage could result if instructions are not followed.**

**NOTICE**

**Indicates that equipment or property damage could result if instructions are not followed.**

**NOTE:** Gives helpful information.

If a problem should arise, or if you have any questions about the Outboard Motor, consult an authorized Honda Outboard Motor dealer.

**▲ WARNING**

**Honda Outboard Motors are designed to give safe and dependable service if operated according to instructions. Read and understand the Owner's Manual before operating the Outboard Motor. Failure to do so could result in personal injury or equipment damage.**

- **Have your dealer install the tiller handle.**
- **The illustration may vary according to the type.**

Honda Motor Co., Ltd. 2011, All Rights Reserved





This Owner's Manual is using the following type names when it describes the operations special to a type.

- Tiller handle type: H type
- Remote control type: R type
- Gas-assisted tilt type: G type
- Power trim/tilt type: T type

The remote control type is classified into the following three categories according to the control box position.

- Side-mount type: R1 type
- Panel-mount type
- Top-mount type

This Owner's Manual describes with the side-mount type remote control box.

Check the type of your outboard motor and read this Owner's Manual thoroughly before operation. Texts with no type indication are the information and/or procedures common to all types.

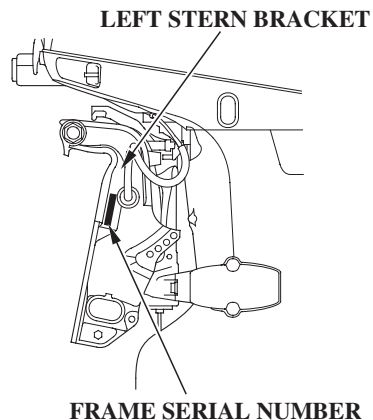

Record the frame and engine serial numbers for your reference. Refer to the serial numbers when ordering parts, and when making technical or warranty inquiries.

The frame serial number is stamped on a plate attached on left stern bracket.

Frame serial number:  
\_\_\_\_\_

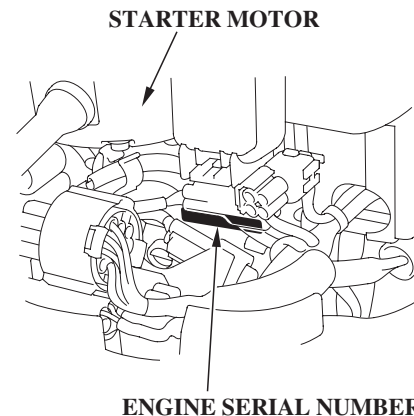

The engine serial number is stamped on the cylinder block under the starter motor which is located in front of the engine.

Engine serial number:  
\_\_\_\_\_

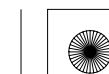



Model Type	BF40D						
	SRTU SRTD	LHD	LHTD	LRTU LRTD	LRTL	SRTZ	LRTZ
Shaft Length (Transom Height)	S	L	L	L	L	S	L
Tiller Handle		●	●				
Remote Control	●			●	●	*	*
Gas-assisted Tilt		●					
Power Trim/Tilt	●		●	●	●	●	●
Tachometer	●	*	●	●	*	*	*
Trim meter	●		●	●	*	*	*

**NOTE:** Note that the types of the outboard motor differ according to the countries where they are sold.



BF40D is provided with the following types according to the shaft length, control system, and tilt system.

- According to Shaft Length  
S: Short Shaft  
L: Long Shaft
- \*: Optional Equipment

TYPE CODE Example

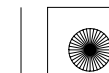
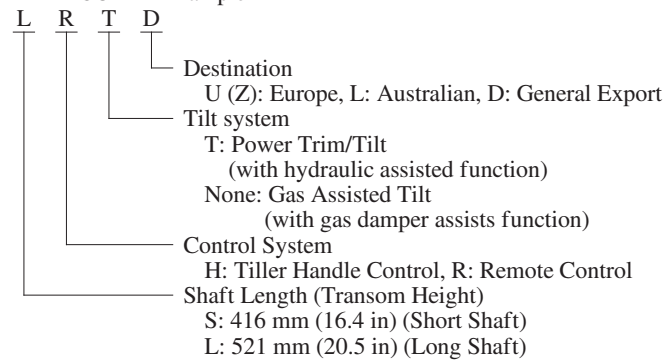



Model	BF50D													
Type	SRTU SRTD	LHD	LHTD	LRD	LRTU LRTD	LRTL	YHD	YHTD	YRTD	XHD	XRTD	XRTL	SRTZ	LRTZ
Shaft Length (Transom Height)	S	L	L	L	L	L	Y	Y	Y	X	X	X	S	L
Tiller Handle		●	●				●	●		●				
Remote Control	●			●	●	●			●		●	●	*	*
Gas-assisted Tilt		●		●			●			●				
Power Trim/Tilt	●		●		●	●		●	●		●	●	●	●
Tachometer	●	*	●	*	●	*	*	●	●	*	●	*	*	*
Trim meter	●		●		●	*		●	●		●	*	*	*

**NOTE:** Note that the types of the outboard motor differ according to the countries where they are sold.



BF50D is provided with the following types according to the shaft length, control system, and tilt system.

- According to Shaft Length
  - S: Short Shaft
  - L: Long Shaft
  - Y: Semi-Long Shaft
  - X: Extra Long Shaft
- \* : Optional Equipment

TYPE CODE Example

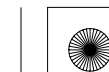
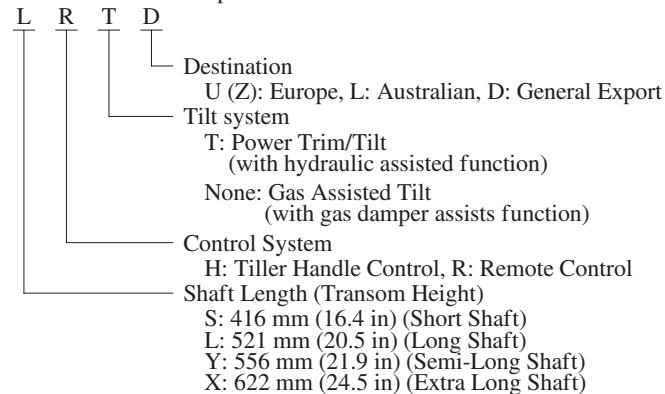



# CONTENTS

1. SAFETY .....	8	Common	
SAFETY INFORMATION .....	8	Tilt Lock Lever .....	33
2. SAFETY LABEL LOCATIONS .....	11	Oil Pressure Indicator/Buzzer .....	33
CE mark location .....	13	Overheat Indicator/Buzzer .....	34
3. COMPONENT IDENTIFICATION .....	14	ACG Indicator/Buzzer .....	34
4. CONTROLS AND FEATURES .....	20	PGM-FI Indicator/Buzzer .....	35
H type		Trim Tab .....	36
Engine Switch .....	20	Anode .....	36
Shift Lever .....	20	Cooling Water Check Hole .....	37
Throttle Grip .....	21	Cooling Water Intake Port .....	37
Throttle Friction Adjuster .....	21	Engine Cover Fixing Lever .....	38
Emergency Stop Switch .....	22	Fuel Filler Cap .....	38
Emergency Stop Switch Lanyard/Clip .....	22	Fuel Gauge .....	39
Steering Friction Adjuster .....	23	Fuel Line Connector .....	39
R type		Tachometer .....	39
Remote Control Lever .....	24	Digital Tachometer .....	40
Neutral Release Lever .....	25	Digital Speedometer .....	40
Engine Switch .....	25	Interface Coupler .....	40
Fast Idle Lever .....	26	5. INSTALLATION .....	41
Emergency Stop Switch .....	26	Transom Height .....	41
Emergency Stop Switch Lanyard/Clip .....	27	Location .....	42
Spare Emergency Stop Switch Clip .....	28	Installation Height .....	42
T type		Outboard Motor Installation .....	43
Power Trim/Tilt Switch .....	29	Outboard Motor Angle Inspection (Cruising) .....	44
Trim Meter .....	30	Outboard Motor Angle Adjustment .....	45
Power Tilt Switch .....	30	Battery Connections .....	46
Manual Relief Valve .....	31	Remote Control Installation .....	48
G type		Remote Control Box Location .....	48
Tilt Lever .....	32	Remote Control Cable Length .....	49
Transom Angle Adjusting Rod .....	32	Propeller Selection .....	49

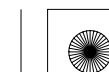



# CONTENTS

6. PRE-OPERATION CHECKS .....	50	Power Tilt Switch .....	88
Engine Cover Removal/Installation .....	50	Trim Tab Adjustment .....	89
Engine Oil .....	51	Engine Protection System .....	90
Fuel .....	52	Engine Oil Pressure, Overheat, PGM-FI and	
GASOLINE CONTAINING ALCOHOL .....	53	ACG Warning Systems .....	90
Propeller and Cotter Pin Inspection .....	54	Over-rev Limiter .....	95
Tiller Handle Height/Angle Adjustment (H type) .....	55	Anode .....	95
Steering Handle Friction (H type) .....	56	Shallow Water Operation .....	96
Remote Control Lever Friction (R type) .....	56	9. STOPPING THE ENGINE .....	97
Fuel Filter .....	56	Emergency Engine Stop .....	97
Battery .....	57	Normal Engine Stop	
Other Checks .....	58	(H type) .....	98
7. STARTING THE ENGINE .....	59	(R type) .....	99
Fuel Line Connection .....	59	10. TRANSPORTING .....	100
Fuel Priming .....	60	Fuel Line Disconnection .....	100
Starting the Engine (H type) .....	61	Transporting .....	101
Starting the Engine (R type) .....	65	Trailing .....	103
Emergency Starting .....	68	11. CLEANING AND FLUSHING .....	104
8. OPERATION .....	74	With Water Hose Joint (Optional part) .....	104
Break-in Procedure .....	74	Without Water Hose Joint .....	105
H type		12. MAINTENANCE .....	107
Gear Shifting .....	75	Tool Kit and Spare Parts .....	108
Steering .....	76	MAINTENANCE SCHEDULE .....	109
Cruising .....	77	Engine Oil .....	111
Trimming the Outboard Motor .....	79	Spark Plugs .....	113
R type		Battery .....	115
Gear Shifting .....	81	Lubrication .....	118
Cruising .....	82	Fuel Filter .....	119
Common		Fuel Tank and Tank Filter .....	122
Trim Meter .....	84	EMISSION CONTROL SYSTEM .....	123
Tilting the Outboard Motor .....	85	Fuse .....	124
Moorage .....	87	Propeller .....	125
Manual Relief Valve .....	88	Submerged Outboard Motor .....	127





# CONTENTS

13. STORAGE.....	129
Fuel .....	129
Vapor Separator Draining .....	130
Engine Oil.....	131
Battery Storage.....	132
Outboard Motor Position.....	133
14. DISPOSAL .....	134
15. TROUBLESHOOTING .....	135
16. SPECIFICATIONS.....	136
17. MAJOR Honda DISTRIBUTOR ADDRESSES .....	142
18. "EC DECLARATION OF CONFORMITY"	
CONTENT OUTLINE .....	145
19. INDEX .....	150
WIRING DIAGRAM .....	153
	Inside Back Cover

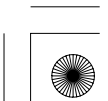
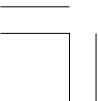



# 1. SAFETY

## SAFETY INFORMATION

For your safety and the safety of others, pay special attention to these precautions.

### Operator Responsibility



- **Honda outboard motor is designed to give safe and dependable service if operated according to instructions. Read and understand the Owner's Manual before operating the outboard motor. Failure to do so could result in personal injury or equipment damage.**

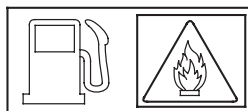

- **Gasoline is harmful or fatal if swallowed. Keep the fuel tank out of reach of children.**
- **Gasoline is extremely flammable and is explosive under certain conditions. Refuel in a well-ventilated area with the engine stopped.**
- **Do not smoke or allow flames or sparks where the engine is refueled or where gasoline is stored.**

- **Do not overfill the fuel tank. After refueling make sure that the fuel tank cap is closed properly and securely.**
- **Be careful not to spill any fuel while refueling. Spilled fuel or fuel vapor may ignite. If any fuel is spilled make sure that the area is dry before starting the engine.**







## SAFETY



**Shift to the neutral position and then shift to the reverse position at low engine speed. Do not shift to the reverse position suddenly at high engine speed.**



**Moving parts can injure you. Install the engine cover after emergency starting the engine. Do not operate the outboard motor without the engine cover.**

- Know how to stop the engine quickly in case of emergency. Understand the use of all controls.
- Do not exceed the boat manufacturer's power recommendation, and be sure that the outboard motor is properly mounted.
- Never permit anyone to operate the outboard motor without proper instruction.
- Stop the engine immediately if anyone falls overboard.
- Do not run the engine while the boat is near anyone in the water.
- Attach the emergency stop switch lanyard securely to the operator.
- Before operating the outboard motor, familiarize yourself with all laws and regulations relating to boating and the use of outboard motors.
- Do not attempt to modify the outboard motor.

- Always wear a life-jacket when on board.
- Do not operate the outboard motor without the engine cover. Exposed moving parts can cause injury.
- Do not remove any guards, labels, shields, covers or safety devices; they are installed for your safety.





## SAFETY

---

### Fire and Burn Hazards

Gasoline is extremely flammable, and gasoline vapor can explode. Use extreme care when handling gasoline. **KEEP OUT OF REACH OF CHILDREN.**

- Remove the fuel tank from the boat for refueling.
- Refuel in a well-ventilated area with the engine stopped. Keep flames and sparks away, and do not smoke in the area.
- Refuel carefully to avoid spilling fuel. Avoid overfilling the fuel tank (there should be no fuel in the filler neck). After refueling, tighten the fuel filler cap securely. If any fuel is spilled, make sure the area is dry before starting the engine.

The engine and exhaust system become very hot during operation and remain hot for a while after stopping. Contact with hot engine components can cause burns and may ignite some materials.

- Avoid touching a hot engine or exhaust system.
- Allow the engine to cool before performing maintenance or transporting.

### Carbon Monoxide Poisoning Hazard

Exhaust contains poisonous carbon monoxide, a colorless and odorless gas. Breathing exhaust can cause loss of consciousness and may lead to death.

- If you run the engine in an area that is confined, or even partially enclosed, the air can become contaminated with a dangerous amount of exhaust gas. To keep exhaust gas from building up, provide adequate ventilation.





## 2. SAFETY LABEL LOCATIONS

### [Equipped type]

These labels are in the locations shown.

They warn you of potential hazards that can cause serious injury.

Read the labels and safety notes and precautions described in this manual carefully.

If a label comes off or becomes hard to read, contact your Honda outboard motor dealer for a replacement.

#### READ OWNER'S MANUAL

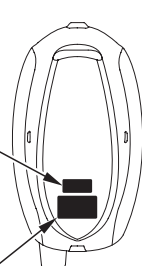

#### READ OWNER'S MANUAL EMERGENCY ENGINE STARTING

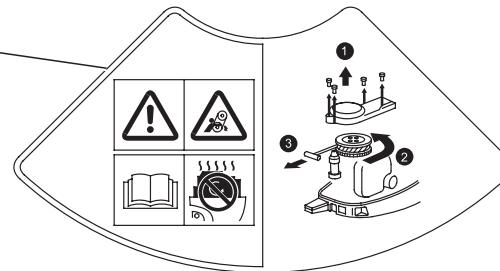

#### READ OWNER'S MANUAL GEAR SHIFTING

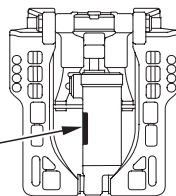
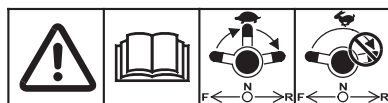

#### AT CAUTION



[G type]

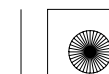



# SAFETY LABEL LOCATIONS

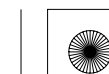
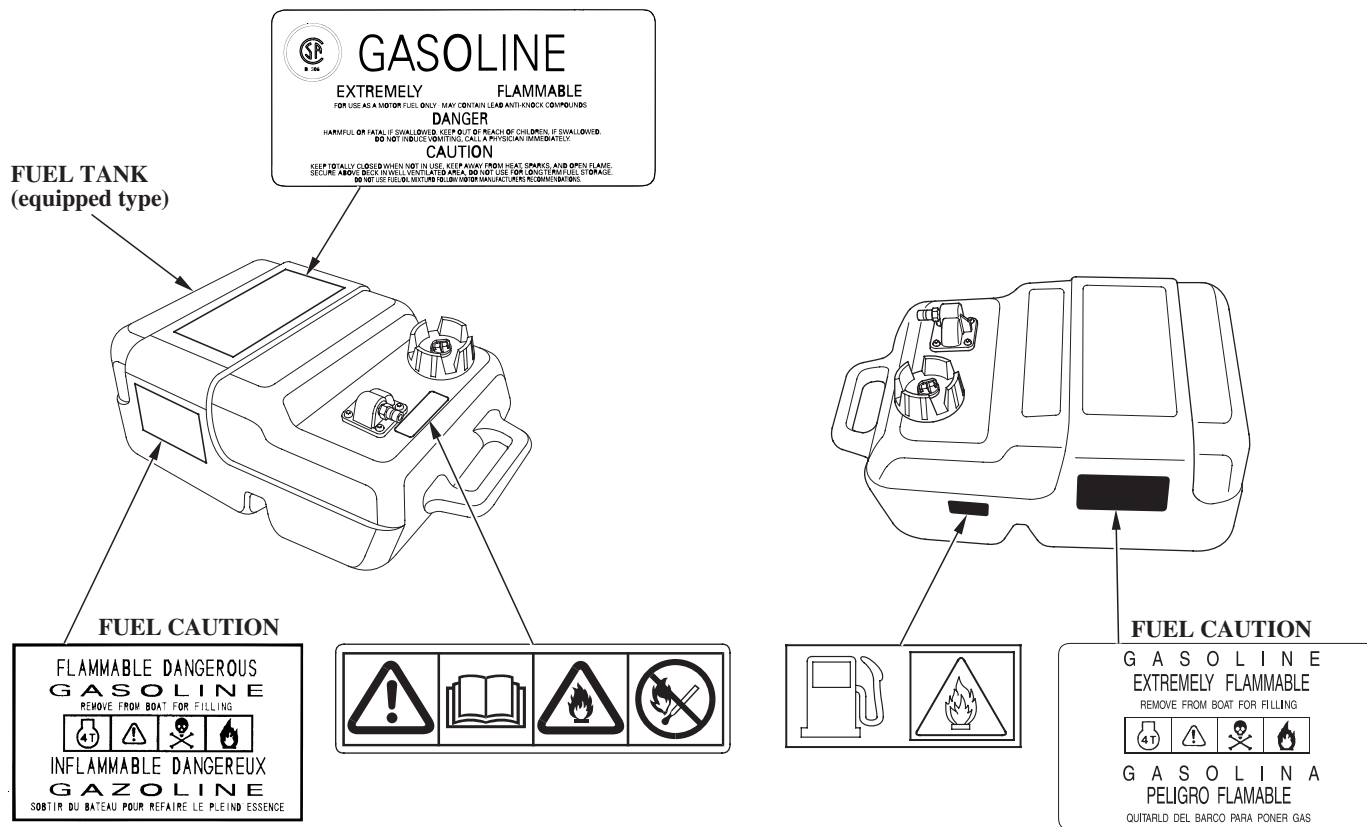



## SAFETY LABEL LOCATIONS

### CE mark location [U and Z types only]

#### CE MARK

**BF40D:**

	year of Mfg. 		<b>BF 40D</b> <small>(H-NX0808G1)</small>
Rated power     29.4 kW			
Mass             96.0-102.0 kg			
Honda Motor Co., Ltd. 2-1-1 Minamiosayama, Minato-ku, Tokyo, Japan		Honda Motor Europe Ltd. Aalst Office Wijngaardveld 1 (Noord V), 9300 Aalst, BELGIUM	

↑  
Manufacturer and address

←  
Dry weight  
(with propeller, without  
battery cable)

←  
Name and address of  
authorized representative

**BF50D:**

	year of Mfg. 		<b>BF 50D</b> <small>(H-NX0808G1)</small>
Rated power     36.8 kW			
Mass             96.0-102.0 kg			
Honda Motor Co., Ltd. 2-1-1 Minamiosayama, Minato-ku, Tokyo, Japan		Honda Motor Europe Ltd. Aalst Office Wijngaardveld 1 (Noord V), 9300 Aalst, BELGIUM	

↑  
Manufacturer and address

←  
Dry weight  
(with propeller, without  
battery cable)

←  
Name and address of  
authorized representative

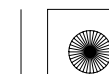
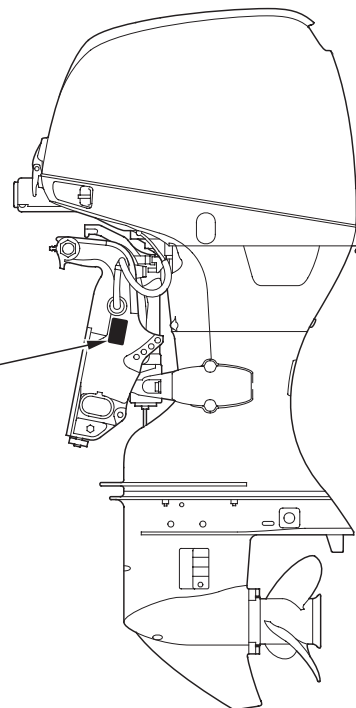



### 3. COMPONENT IDENTIFICATION

[H (Tiller Handle) type]

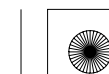
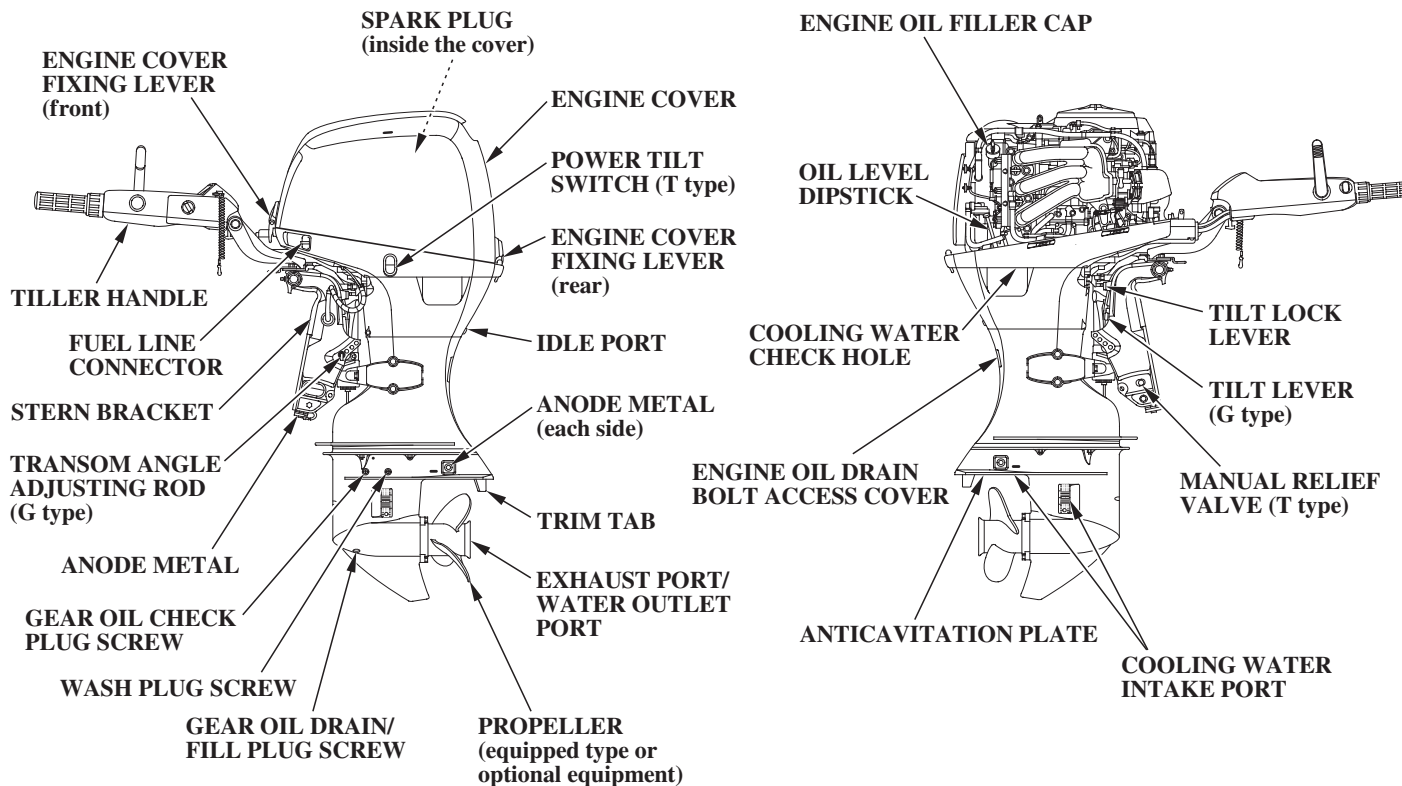



# COMPONENT IDENTIFICATION

## TILLER HANDLE

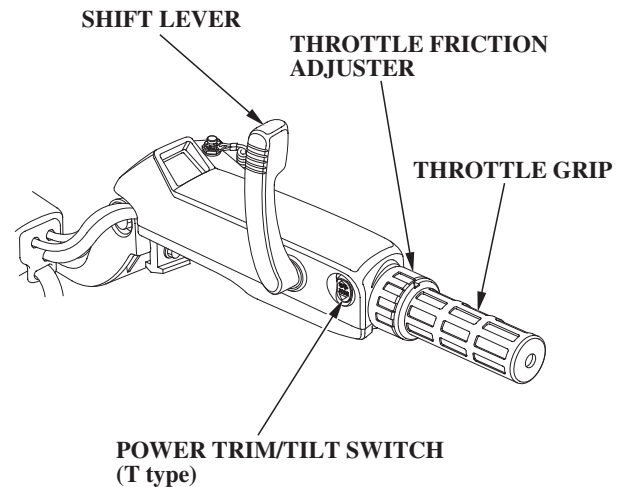
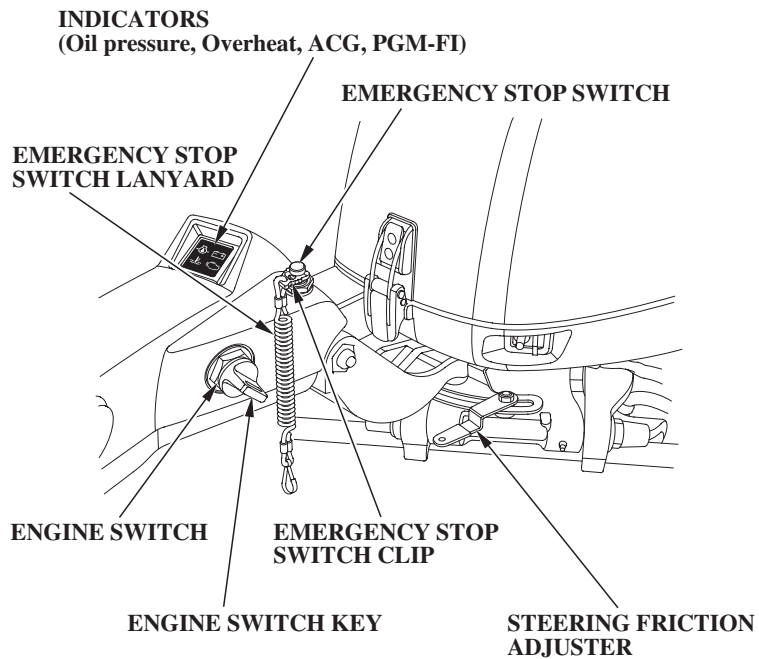

### SPARE EMERGENCY STOP SWITCH CLIP



Store the spare emergency stop switch clip in the tool bag.

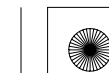



# COMPONENT IDENTIFICATION

[R (Remote Control) type]

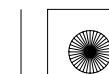
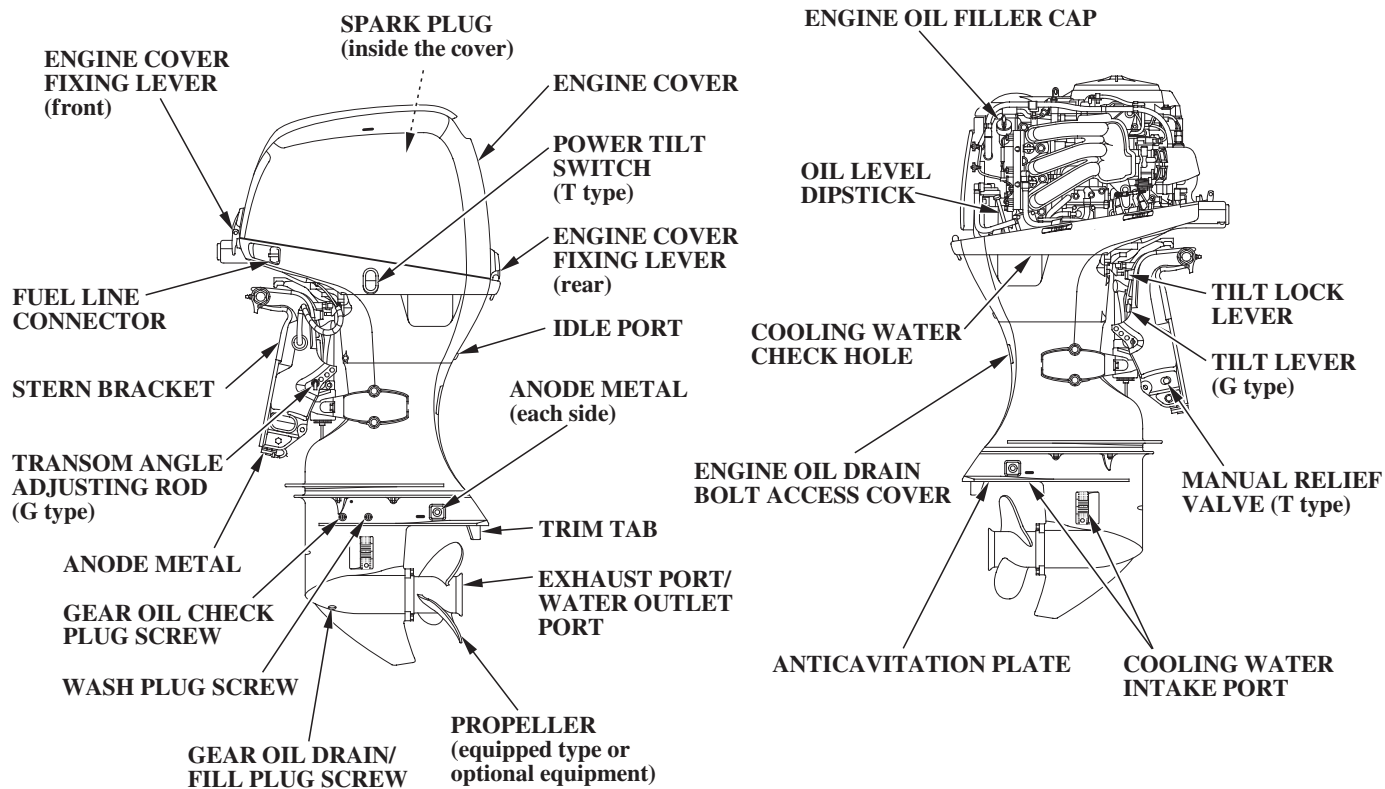





## COMPONENT IDENTIFICATION

### REMOTE CONTROL BOX (equipped type or optional equipment)

#### SIDE-MOUNT TYPE (R1 type)

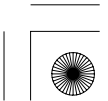
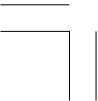
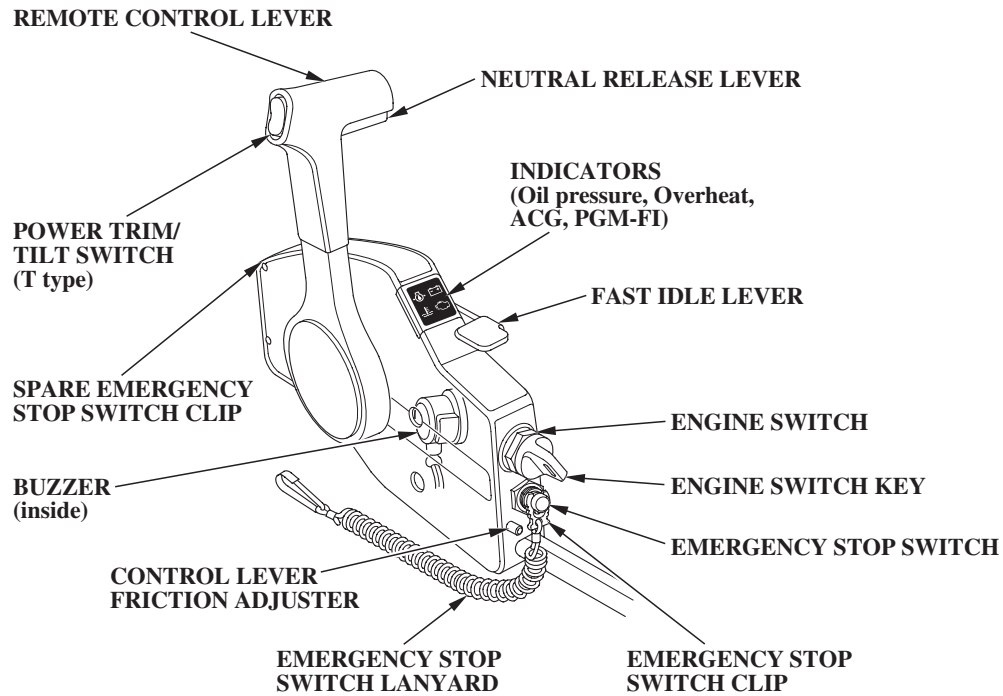



## COMPONENT IDENTIFICATION

---

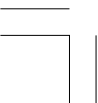
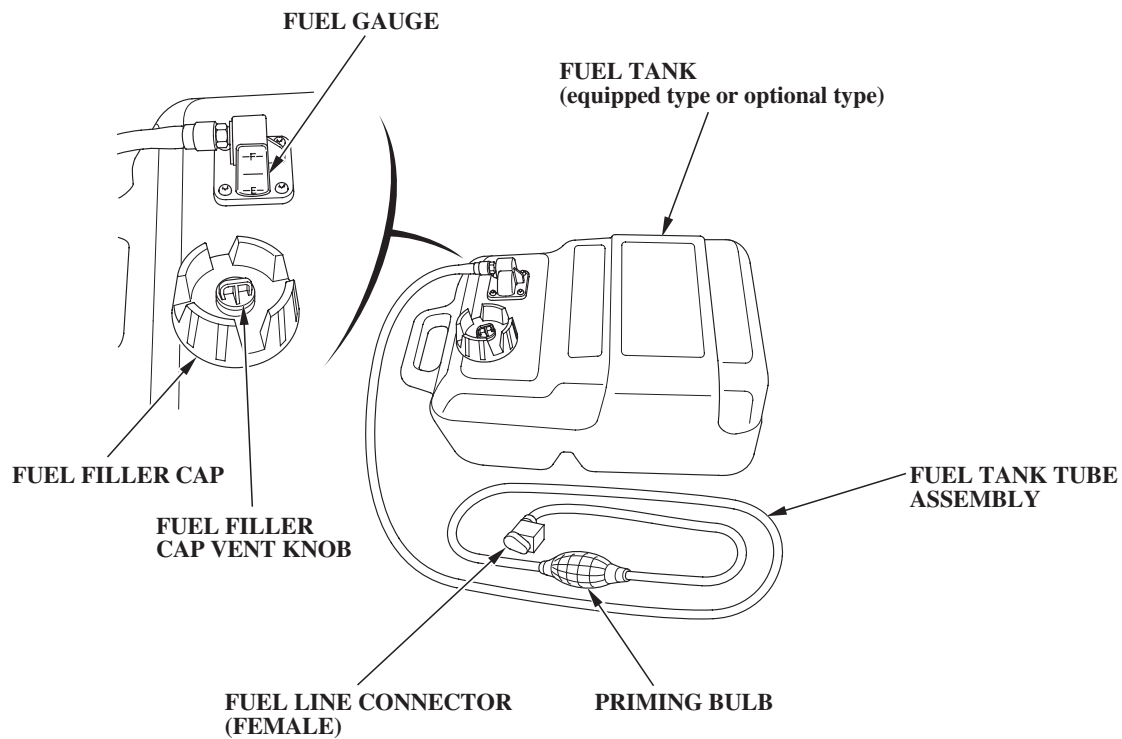

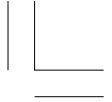

## COMPONENT IDENTIFICATION

**TACHOMETER**  
(equipped type or optional equipment)

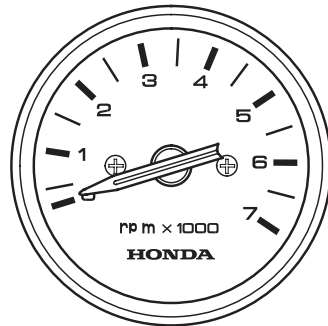

**TRIM METER**  
(equipped type or optional equipment)

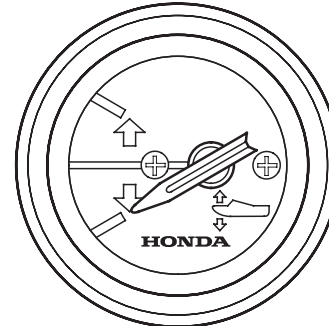

**DIGITAL TACHOMETER**  
(optional equipment: R type)

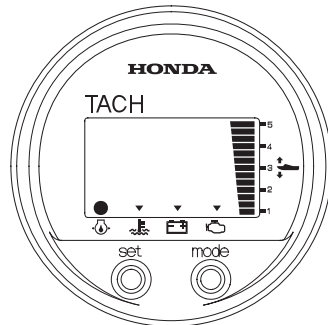

**DIGITAL SPEEDOMETER**  
(optional equipment: R type)

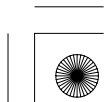
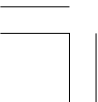
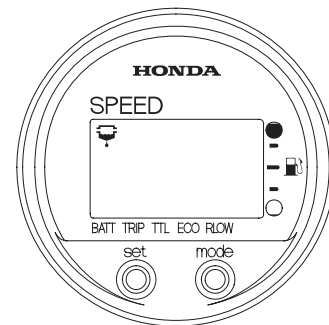



## 4. CONTROLS AND FEATURES (H type)

### Engine Switch (Ignition Switch)

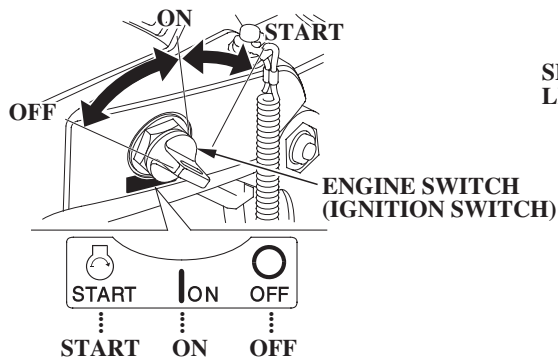

This tiller handle is equipped with an automotive type ignition switch.

Key positions:

- START: to start the engine.
- ON: to run the engine after starting.
- OFF: to stop the engine (IGNITION OFF).

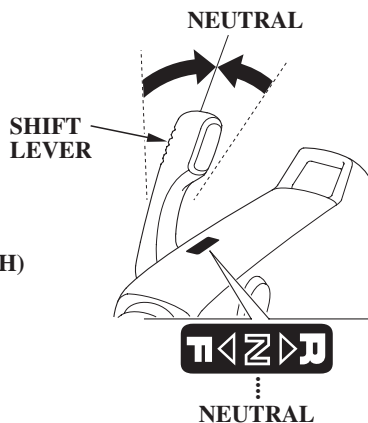

#### NOTICE

**Do not leave the engine switch (ignition switch) ON (key in ON position) when the engine is not running as the battery will discharge.**

#### NOTE:

The starter motor will not work unless the shift lever is in the NEUTRAL position.

### Shift Lever

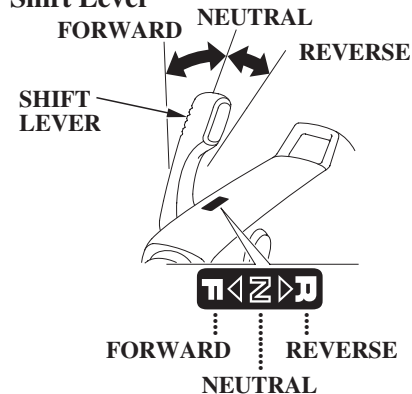

Use the shift lever to run the boat in forward or reverse gear, or to cut off the engine power from the propeller. There are three positions for the shift lever.

- FORWARD: The boat moves ahead.
- NEUTRAL: The engine power is cut off from the propeller. The boat does not move.
- REVERSE: The boat reverses.

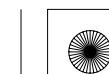



## CONTROLS AND FEATURES (H type)

### Throttle Grip

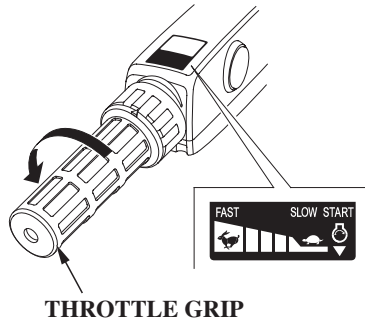

Turn the grip clockwise or counterclockwise to adjust the engine speed. Turning the grip in the direction shown by arrow increases the engine speed.

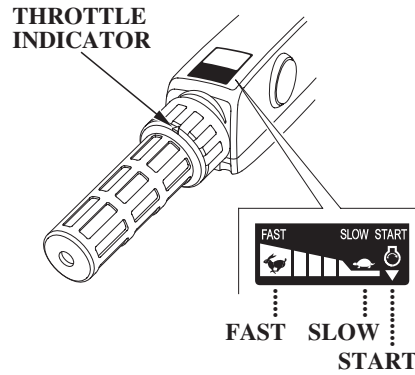

The curve on the grip indicates the engine speed.

### Throttle Friction Adjuster

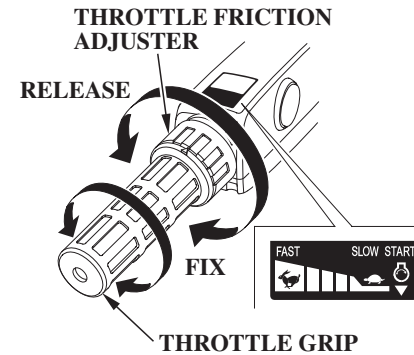

The throttle friction adjuster adjusts resistance to throttle grip rotation.

Turn the adjuster clockwise to increase friction for holding a throttle setting while cruising.

Turn the adjuster counterclockwise to decrease friction for easy throttle grip rotation.





## CONTROLS AND FEATURES (H type)

### Emergency Stop Switch

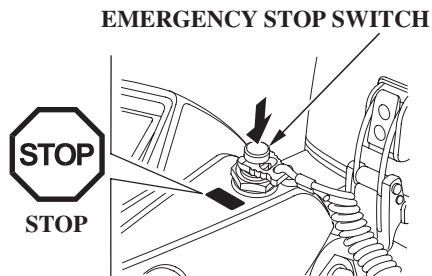

Press the emergency stop switch to stop the engine.

### Emergency Stop Switch Lanyard/Clip

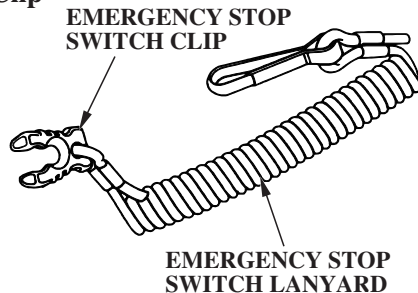

The emergency stop switch lanyard is provided to stop the engine immediately when the operator falls overboard or away from the outboard motor.

The engine stops when the clip at the end of the emergency stop switch lanyard is pulled out of the emergency stop switch.

When operating the outboard motor, be sure to attach one end of the emergency stop switch lanyard securely to the operator.

### EMERGENCY STOP SWITCH

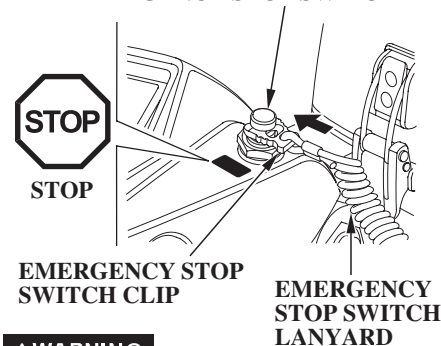

#### **▲WARNING**

**If the emergency stop switch lanyard is not set, the boat might run out of control when the operator, for example, falls overboard and is not able to operate the outboard motor.**

For the sake of the operator's and the passengers' safety, be sure to set the emergency stop switch clip located at one end of the emergency stop switch lanyard with the emergency stop switch. Attach the other end of the emergency stop switch lanyard securely to the operator.





## CONTROLS AND FEATURES (H type)

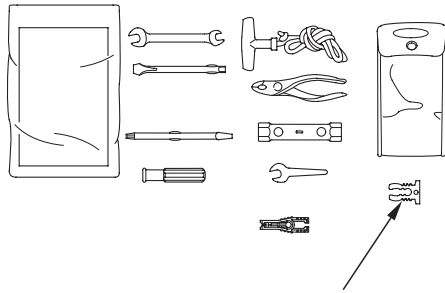

**SPARE EMERGENCY STOP SWITCH CLIP**

**NOTE:**

The engine does not start unless the emergency stop switch clip is set on the emergency stop switch.

Store the spare emergency stop switch clip in the tool bag. Use the spare emergency stop switch clip to make the disabled engine start when the emergency stop switch lanyard is not available as, for example, when the operator falls overboard.

### Steering Friction Adjuster

#### STEERING FRICTION ADJUSTER

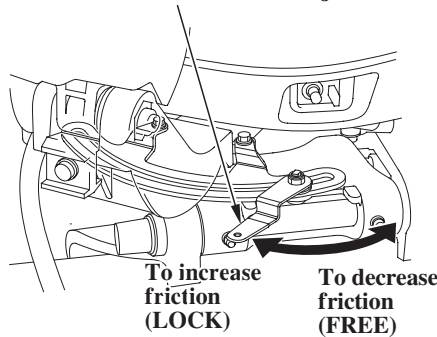

The steering friction adjuster adjusts steering resistance.

Less friction allows the outboard motor to turn more easily. More friction helps to hold a steady course while cruising or to prevent the outboard motor from swinging while trailering the boat.

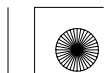



## CONTROLS AND FEATURES (R type)

### Remote Control Lever (R1 type)

#### REMOTE CONTROL LEVER

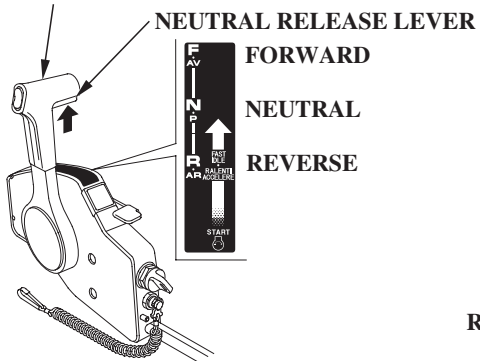

Shifting gear into forward, reverse, or neutral and the engine speed adjustment can be performed with the remote control lever. It is necessary to pull up the neutral release lever to operate the remote control lever.

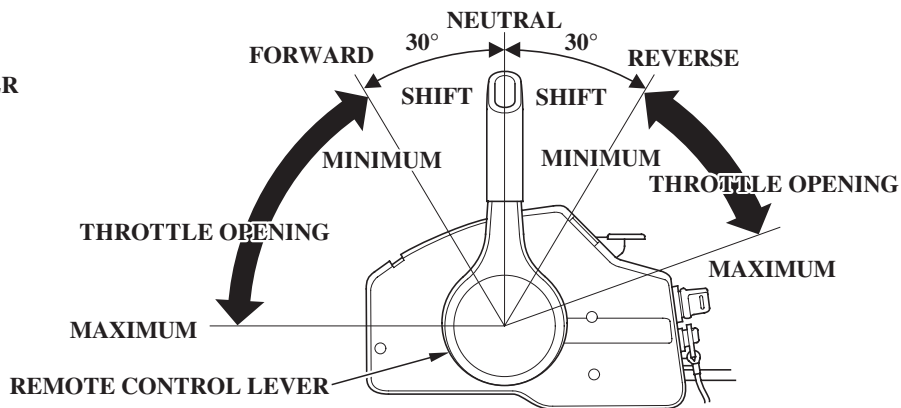

#### FORWARD:

Moving the lever to the FORWARD position (i.e. approximately 30° from the NEUTRAL position) engages the gear into forward. Moving the lever further from the FORWARD position will increase the throttle opening and the boat forward speed.

#### NEUTRAL:

Engine power is cut off from the propeller.

#### REVERSE:

Moving the lever to the REVERSE position (i.e. approximately 30° from the NEUTRAL position) engages the gear into reverse. Moving the lever further from the REVERSE position will increase the throttle opening and the boat reverse speed.







## CONTROLS AND FEATURES (R type)

### Neutral Release Lever

(R1 type)

REMOTE CONTROL LEVER

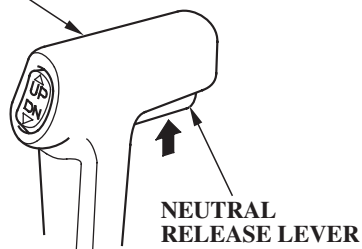

The neutral release lever is set on the remote control lever to prevent an accidental operation of the remote control lever.

The remote control lever does not operate unless it is moved while pulling the neutral release lever up.

### Engine Switch (Ignition Switch)

(R1 type)

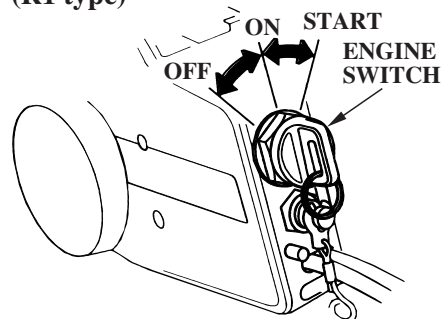

This remote control is equipped with an automotive type ignition switch. On the side-mount type (R1 type), the engine switch locates on your side near the remote control box.

Key positions:

- START: to start the engine.
- ON: to run the engine after starting.
- OFF: to stop the engine (IGNITION OFF).

#### NOTICE

**Do not leave the engine switch (ignition switch) ON (key in ON position) when the engine is not running as the battery will discharge.**

#### NOTE:

The starter motor will not work unless the remote control lever is in the NEUTRAL position, and the clip is in the emergency stop switch.

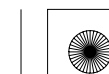



## CONTROLS AND FEATURES (R type)

### Fast Idle Lever (R1 type)

The fast idle lever is only needed for starting carbureted outboard models. The BF40D and BF50D models use programmed fuel injection so, this lever will not be needed for starting.

After the engine starts and if the outside temperature is below 5°C (41°F), the fast idle lever/fast idle button can be used to accelerate engine warm up.

(R1 type)

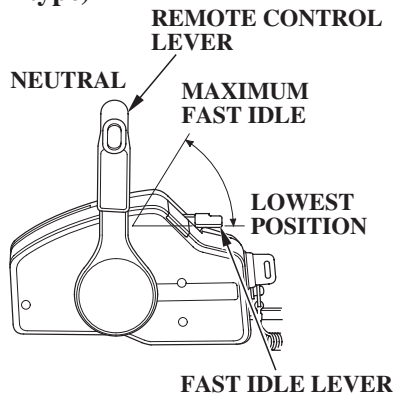

The fast idle lever will not move unless the remote control lever is in the NEUTRAL position. Conversely, the remote control lever will not move unless the fast idle lever is in the lowest position.

Lower the fast idle lever to the lowest position to decrease the fast idle.

### Emergency Stop Switch (R1 type)

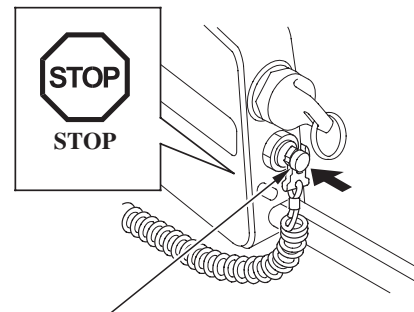

EMERGENCY STOP SWITCH

Press the emergency stop switch to stop the engine.





## CONTROLS AND FEATURES (R type)

### Emergency Stop Switch Lanyard/ Clip

EMERGENCY STOP SWITCH LANYARD

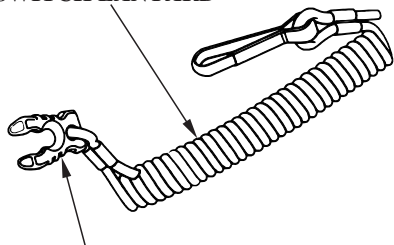

EMERGENCY STOP SWITCH CLIP

The emergency stop switch lanyard is provided to stop the engine immediately in the event the operator should fall overboard or away from the controls.

The emergency stop switch clip must be engaged with the emergency stop switch or the engine will not start. When the emergency stop switch clip becomes disengaged with the emergency stop switch the engine will stop immediately.

#### **▲WARNING**

**If the emergency stop switch lanyard is not set, the boat might run out of control when the operator, for example, falls overboard and is not able to operate the outboard motor.**

For the sake of the operator's and the passenger's safety, be sure to set the emergency stop switch clip located at one end of the emergency stop switch lanyard with the emergency stop switch. Attach the other end of the emergency stop switch lanyard securely to the operator.

### (R1 type)

EMERGENCY STOP SWITCH

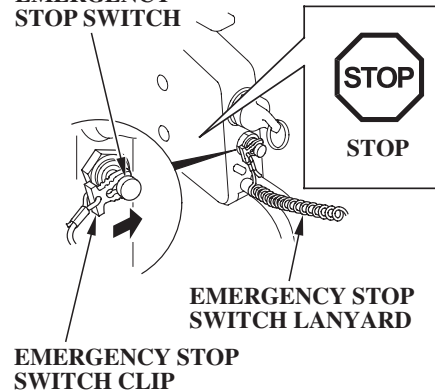

EMERGENCY STOP SWITCH LANYARD

EMERGENCY STOP SWITCH CLIP

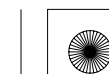



## CONTROLS AND FEATURES (R type)

---

### Spare Emergency Stop Switch Clip (R1 type)

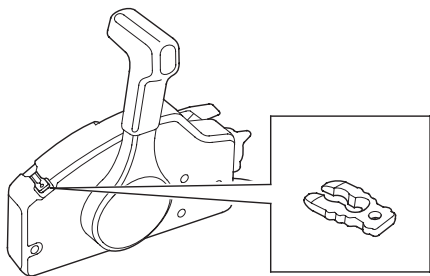

**SPARE EMERGENCY  
STOP SWITCH CLIP**

A spare emergency stop switch clip is provided on the remote control box.

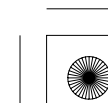
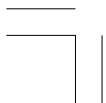



## CONTROLS AND FEATURES (T type)

### Power Trim/Tilt Switch

#### Power Trim

Press the power trim/tilt switch on the remote control lever to adjust the outboard motor trim angle of  $-4^{\circ}$  to  $12^{\circ}$  to maintain proper boat trim. The power trim/tilt switch can be operated while the boat is under way or while stopped.

By using the power trim/tilt switch the operator can change the trim angle of the outboard motor to achieve maximum boat acceleration, speed, stability and maintain optimum fuel consumption.

#### NOTE:

The outboard motor trim angle of  $-4^{\circ}$  to  $12^{\circ}$  is the angle when the outboard motor is installed on the boat at  $12^{\circ}$ .

(H type)

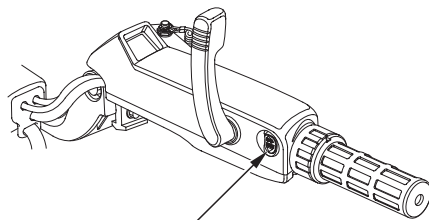

POWER TRIM/TILT SWITCH

(R1 type)

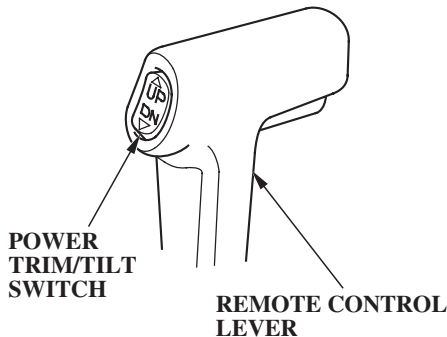

#### NOTICE

Excessive trim/tilt angle during operation can cause the propeller to raise out of the water and cause propeller ventilation and engine over-revving. Excessive trim/tilt angle can also damage the water pump.

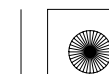



## CONTROLS AND FEATURES (T type)

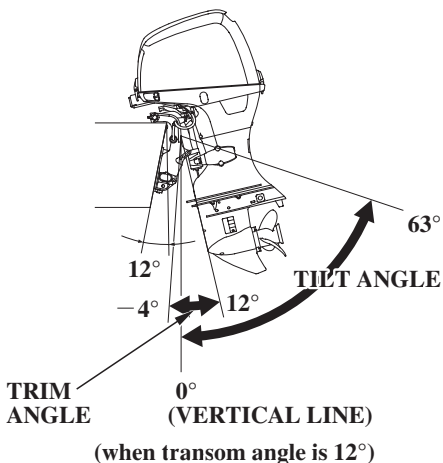

### Power Tilt

Press the power trim/tilt switch to adjust the outboard motor tilt angle of 12° to 63°.

By using the power trim/tilt switch the operator can change the tilt angle of the outboard motor for shallow water operation, beaching, launching from a trailer, or mooring.

Please tilt up simultaneously, when you mount the dual type outboard motor.

### Trim Meter (equipped type or optional equipment)

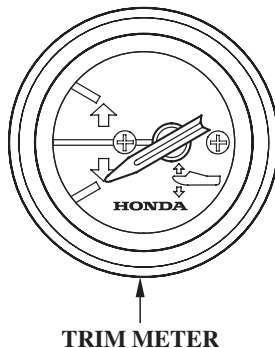

The trim meter has a range of -4° to 12° and indicates the trim angle of the outboard motor. Refer to the trim meter when using the power trim/tilt switch to achieve proper boat performance.

### NOTE:

The outboard motor trim angle of -4° to 12° is the angle when the outboard motor is installed on the boat at 12°.

### Power Tilt Switch (outboard motor pan)

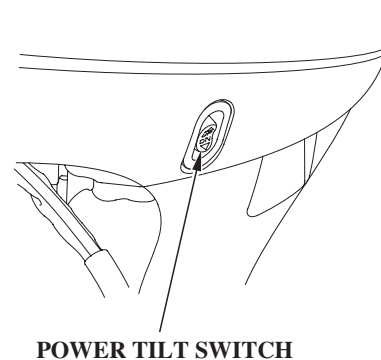

The power tilt switch located on the outboard motor pan is a convenience switch for tilting the outboard motor for trailering, or performing outboard maintenance. This power tilt switch should only be operated with the boat being stopped and engine off.

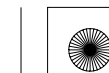



## CONTROLS AND FEATURES (T type)

### Manual Relief Valve

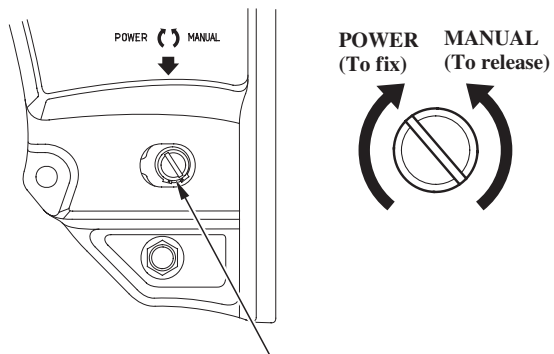

**MANUAL RELIEF VALVE**

If the power trim/tilt switch will not tilt the outboard motor, the outboard motor can be manually tilted up or down by opening the manual relief valve. To tilt the outboard motor manually, turn the manual relief valve under the left stern bracket no more than two and a half turns counterclockwise using a screwdriver.

After tilting the outboard motor, turn the manual relief valve clockwise securely.

Check that nobody is under the outboard motor before opening the manual relief valve. If the manual relief valve is loosened (turned counterclockwise) when the outboard motor is tilted up, the outboard motor will suddenly tilt down.

The manual relief valve must be tightened securely before operating the outboard motor or the outboard motor could tilt up when operating in reverse.

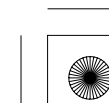
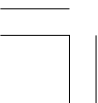



## CONTROLS AND FEATURES (G type)

### Tilt Lever

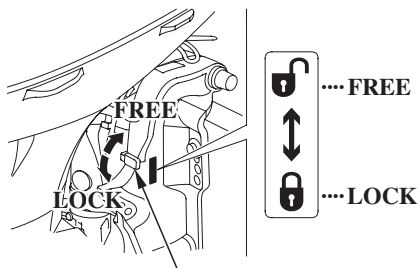

#### TILT LEVER

Use the tilt lever to temporarily raise the outboard motor when the boat is sailing in the shallows, or mooring or anchoring in the shallows.

Raising the tilt lever unlocks the outboard motor and the outboard motor can be tilted. Lowering the tilt lever locks the outboard motor.

#### ▲WARNING

**Be sure to lower the tilt lever and lock the outboard motor before sailing. The outboard motor could rise when sailing in the reverse gear, resulting in an accidental injury to the passenger(s).**

32

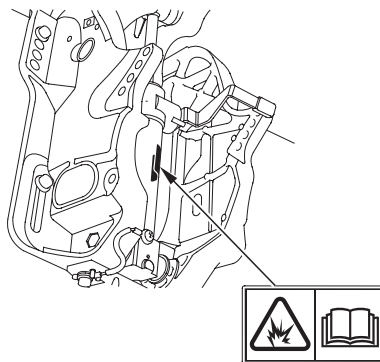

#### ▲WARNING

**Do not disassemble the gas assisted damper assembly as it is filled with the high pressure gas.**

### Transom Angle Adjusting Rod

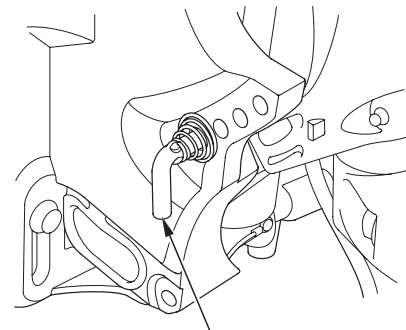

#### TRANSOM ANGLE ADJUSTING ROD

Use the transom angle adjusting rod to adjust the outboard motor angle properly.

The outboard motor angle can be adjusted to the five angles by changing the adjusting rod position.







## CONTROLS AND FEATURES (Common)

### Tilt Lock Lever

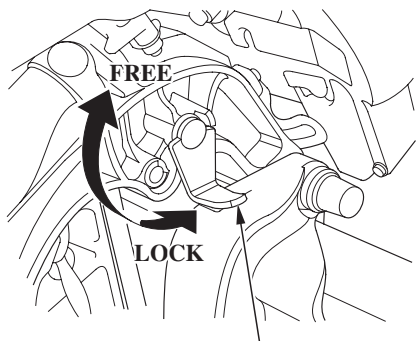

**TILT LOCK LEVER**

Use the tilt lock lever to raise the outboard motor and lock it in the position when the boat is moored or anchored for a long time.

Tilt the outboard motor as far as it goes and move the lock lever in the locking direction.

### Oil Pressure Indicator/Buzzer

The oil pressure indicator turns off and the buzzer sounds when the oil level is low and/or the engine lubrication system is faulty. The engine speed slows down gradually this time.

#### (H type)

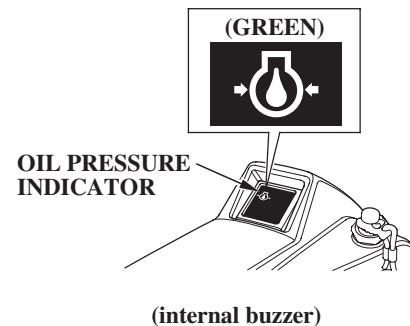

#### (R1 type)

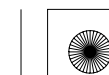
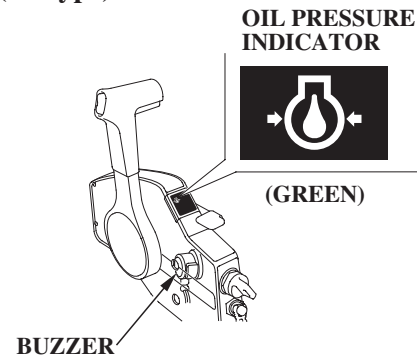



## CONTROLS AND FEATURES (Common)

### Overheat Indicator/Buzzer

The overheat indicator turns on and the buzzer sounds when the engine cooling circuit is faulty. The engine speed slows down this time.

#### (H type)

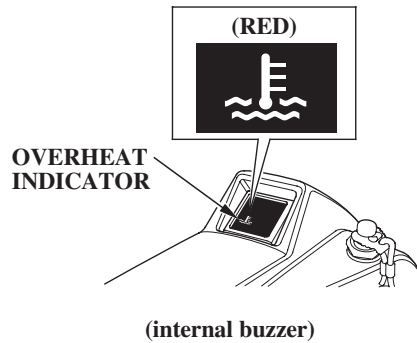

#### (R1 type)

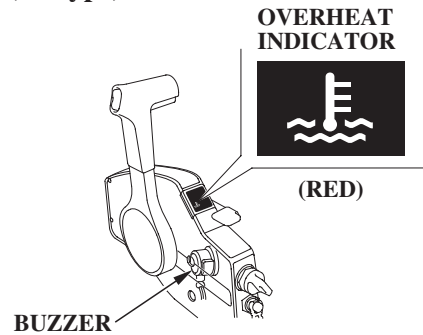

### ACG Indicator/Buzzer

The ACG indicator turns on and the buzzer sounds when the charging system is faulty.

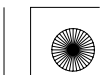



## CONTROLS AND FEATURES (Common)

(H type)

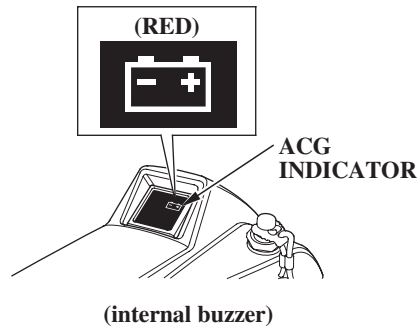

(R1 type)

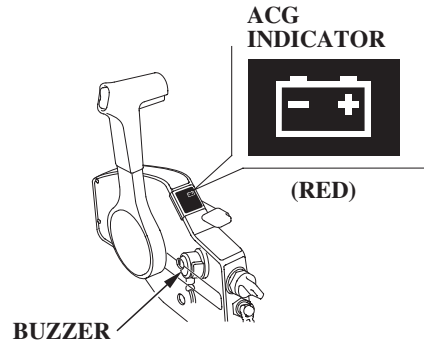

**PGM-FI Indicator/Buzzer**

The PGM-FI indicator turns on and the buzzer sounds when the engine control system is faulty.

(H type)

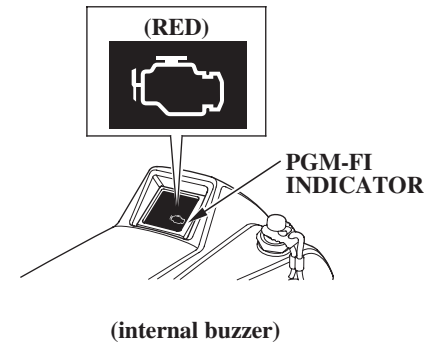

(R1 type)

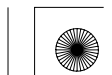
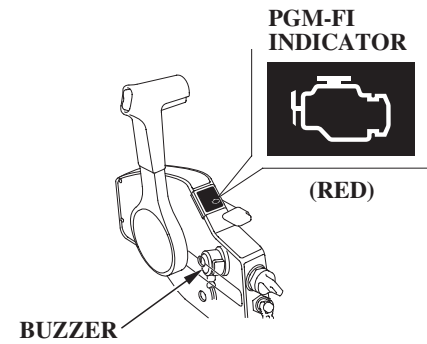



## CONTROLS AND FEATURES (Common)

### Trim Tab

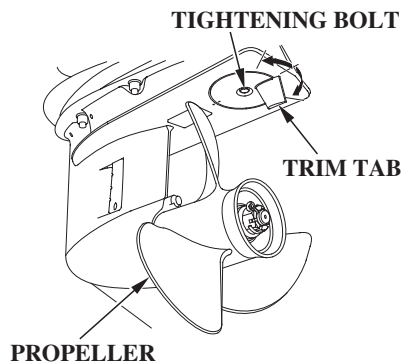

If the steering wheel/handle is pulled to the side while running at full speed, adjust the trim tab so that the boat runs straight ahead.

Loosen the tightening bolt and turn the trim tab right or left to adjust (see page 89 ).

### Anode

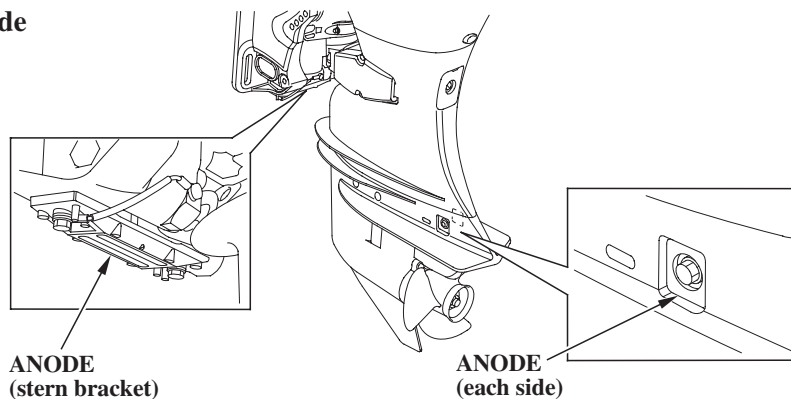

The anode metal is a sacrificed metal which protects the outboard motor from corrosion.

#### NOTICE

**Do not paint the anode. It deteriorates the function of the anode metal, which can lead to rust and corrosion damage to the outboard motor.**

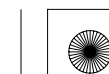



## CONTROLS AND FEATURES (Common)

### Cooling Water Check Hole

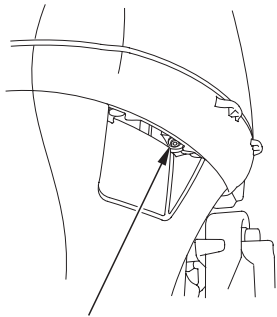

#### COOLING WATER CHECK HOLE

The cooling water is checked here to see whether it is circulating inside the engine properly.

After starting the engine, check at the cooling water check hole whether the cooling water is circulating through the engine.

### Cooling Water Intake Port

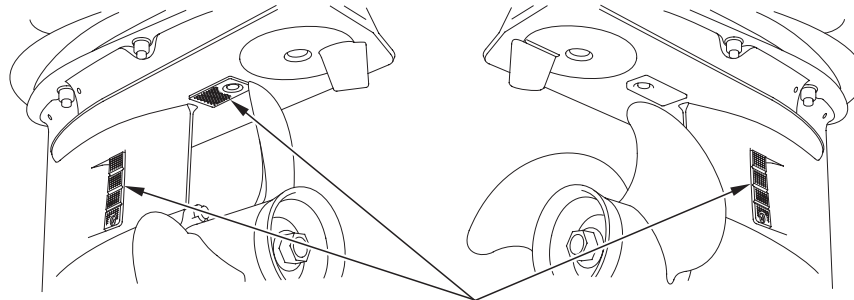

#### COOLING WATER INTAKE PORT

The engine cooling water is drawn into the engine through this port.





## CONTROLS AND FEATURES (Common)

### Engine Cover Fixing Lever (Front/Rear)

(front)

ENGINE COVER  
FIXING LEVER  
(front)

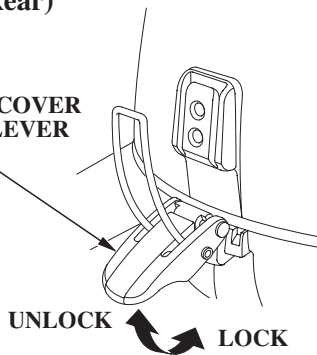

(rear)

ENGINE COVER  
FIXING LEVER  
(rear)

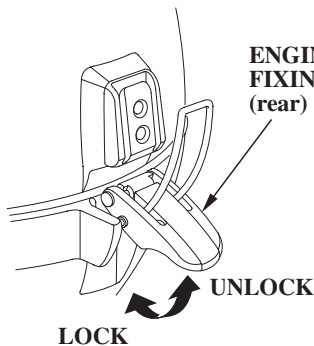

Latch/unlatch the engine cover fixing lever to install or remove the engine cover.

### Fuel Filler Cap (equipped type) (with vent knob)

FUEL FILLER CAP  
VENT KNOB

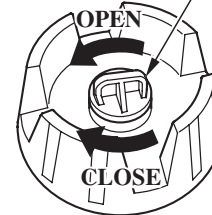

FUEL FILLER CAP

The fuel filler cap vent knob controls air entering and leaving the fuel tank.

When refilling the fuel tank, turn the vent knob counterclockwise to open and remove the fuel filler cap. Turn the vent knob clockwise and close it securely before transporting or storing the fuel tank.

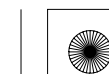



## CONTROLS AND FEATURES (Common)

### Fuel Gauge

FUEL GAUGE

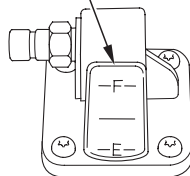

The fuel gauge indicates the fuel level in the tank.

### Fuel Line Connector

FUEL LINE CONNECTOR

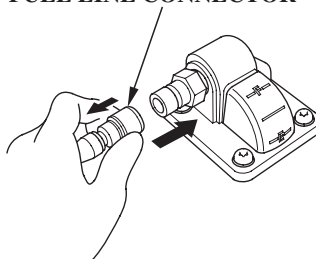

(fuel tank side)

FUEL LINE CONNECTOR

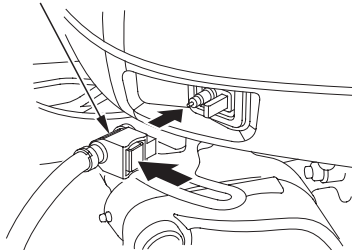

(outboard motor side)

The fuel line connector is used to connect the fuel line between the separate fuel tank and the outboard motor.

### Tachometer (equipped type or optional equipment)

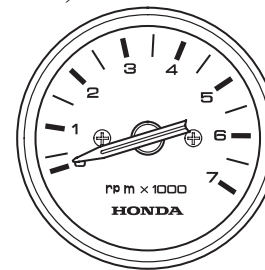

TACHOMETER

The tachometer shows the engine speed in revolutions per minute.

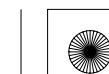



## CONTROLS AND FEATURES (Common)

### Digital Tachometer (optional equipment: R type)

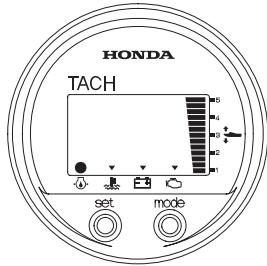

Digital Tachometer includes the following functions.

- Tachometer
- Hour Meter
- Trim Meter
- Oil Pressure Indicator
- Overheat Indicator
- ACG Indicator
- PGM-FI Indicator

Refer to the Operation Guide included with each Digital Tachometer for operation information.

### Digital Speedometer (optional equipment: R type)

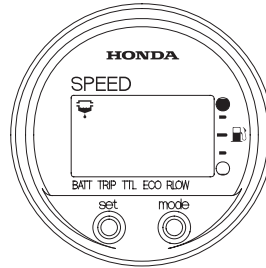

Digital Speedometer includes the following functions.

- Speedometer
- Fuel Level Meter
- Volt Meter
- Tripmeter
- Fuel Integration Meter
- Fuel Economy Meter
- Fuel Flow Meter

Refer to the Operation Guide included with each Digital Speedometer for operation information.

### Interface Coupler

NMEA2000 based information on engine speed, fuel consumption, and various warnings can be read by connecting to the outboard motor with the interface cable (sold separately).

Contact your dealer for more information.

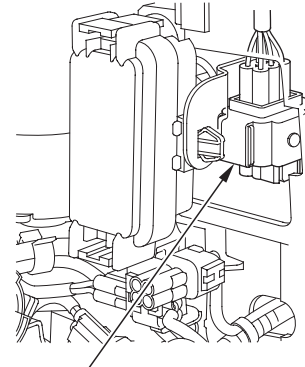

**INTERFACE COUPLER**

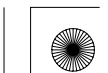





## 5. INSTALLATION

### NOTICE

**Improperly installed outboard motor can result in the outboard motor dropped into the water, boat not able to cruise straight ahead, engine speed not increase, and much fuel consumption.**

We recommend that the outboard motor be installed by an authorized Honda outboard motor dealer. Consult the authorized Honda dealer in your area for the Y-OP (User Optional Parts)/equipments installation and operation.

#### Applicable Boat

Select the boat suitable for the engine power.

#### Engine power:

BF40D: 29.4 kW (40 PS)

BF50D: 36.8 kW (50 PS)

Power recommendation is indicated on most of the boats.

### WARNING

**Do not exceed the boat manufacturer's power recommendation. Damage and injury may result.**

### Transom Height

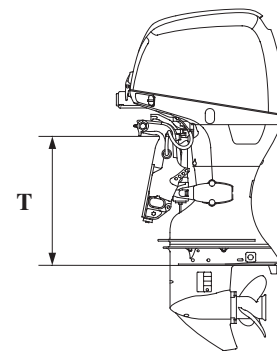

Type:	T (Outboard Motor Transom Height) < when transom angle is 12° >
S:	416 mm (16.4 in)
L:	521 mm (20.5 in)
Y:	556 mm (21.9 in)
X:	622 mm (24.5 in)

Select the outboard motor which is correct for the boat transom height of your boat.

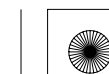



# INSTALLATION

## Location

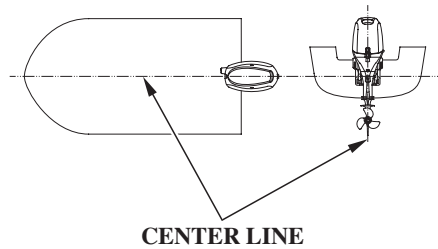

Install the outboard motor at the stern, at the center line of the boat.

## Installation Height

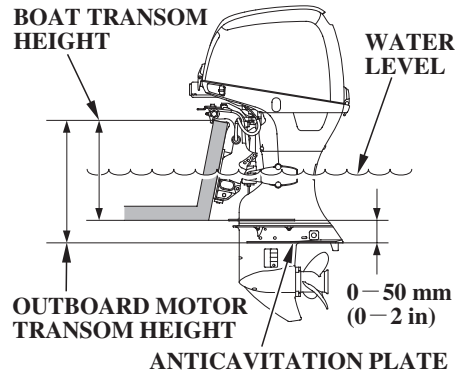

The anticavitation plate of the outboard motor should be 0 – 50 mm (0 – 2 in) below the bottom of the boat. The correct dimensions differ according to the type of boat and the configuration of the bottom of the boat. Follow the manufacture’s recommended installation height.

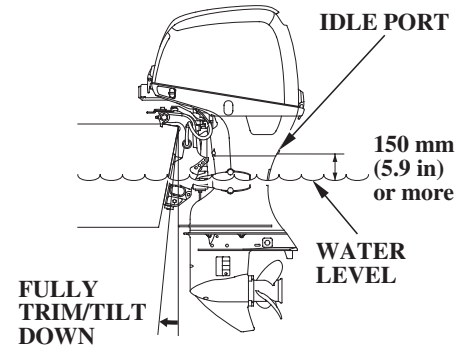

### NOTICE

- The water level must be at least **100 mm (4 in)** above the anticavitation plate, otherwise the water pump may not receive sufficient cooling water, and the engine will overheat.
- Adverse effect to the engine can occur if the installation position of the outboard motor is too low. Trim/tilt down the outboard motor with the boat fully loaded and stop the engine. Check that the idle port is **150 mm (5.9 in)** or more above the water level.





## INSTALLATION

### Outboard Motor Installation

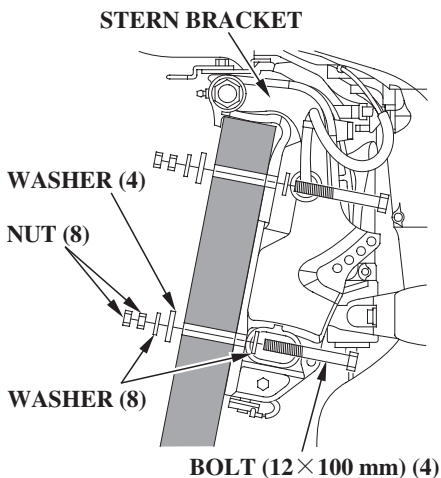

1. Apply the silicone sealant (Three Bond 1216 or equivalent) to the outboard motor mounting holes.
2. Set the outboard motor on the boat and secure with the bolts, washers, and nuts.

### NOTE:

**Standard torque:**  
 15–20 N·m (1.5–2.0 kgf·m ,  
 11–14 lbf·ft)

The standard torque is given just as a guideline. Torque of the nut can be different according to the material of the boat. Consult with an authorized Honda outboard motor dealer.

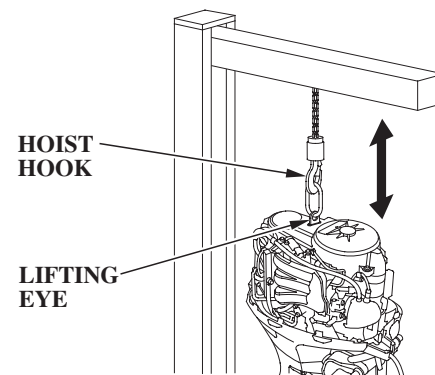

### CAUTION

**Install the outboard motor securely. Loosely mounted outboard motor can result in accidental loss of the outboard motor and damage and injury to the equipment and personnel.**

Before installing the outboard motor on the boat, hang the outboard motor with the hoist or equivalent device by attaching the lifting eye to the outboard.

Use the hoist which allowable load is 250 kg (551 lbs) or above.

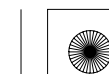



# INSTALLATION

## Outboard Motor Angle Inspection (Cruising)

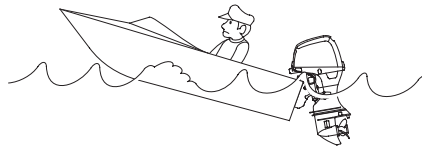

**INCORRECT  
CAUSES BOAT TO “SQUAT”**

Install the outboard motor at the best trim angle for stable cruising and maximum power.

Trim angle too large: Incorrect causes boat to “squat.”

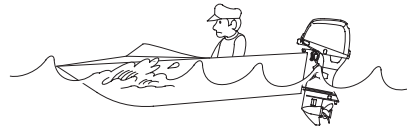

**INCORRECT  
CAUSES BOAT TO “PLOW”**

Trim angle too small: Incorrect causes boat to “plow.”

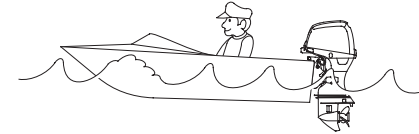

**CORRECT  
GIVES MAXIMUM PERFORMANCE**

The trim angle differs according to the combination of the boat, outboard motor, and propeller, and the operating conditions.

Adjust the outboard motor so that it is perpendicular to the water surface (i.e. axis of the propeller is parallel with the water surface).

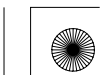



## INSTALLATION

### 〈 Outboard Motor Angle Adjustment (G type) 〉

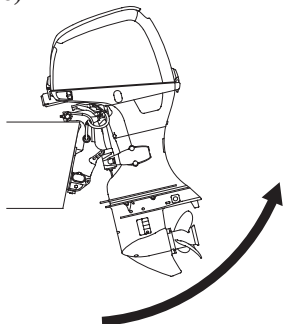

There are five adjusting stages.

1. Tilt the outboard motor to the designated tilt angle.

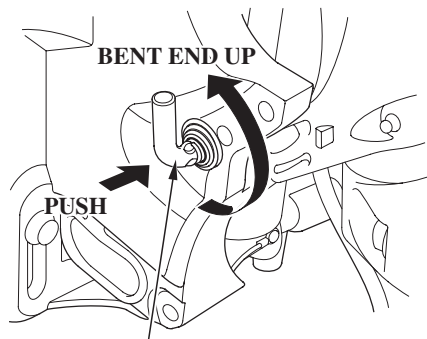

TRANSOM ANGLE ADJUSTING ROD

2. Push in the adjusting rod, twist upwards to the unlocked position and pull out to remove.

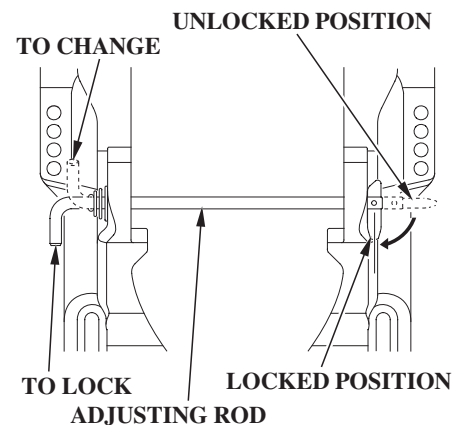

3. Inserting the adjusting rod in the proper hole, twist it down to lock. After locking, pull the adjusting rod and be sure it is not withdrawn.

#### NOTICE

To prevent damage to the outboard motor or boat, make sure the adjusting rod is locked.





## INSTALLATION

### Battery Connections

Use a battery which has CCA (COLD CRANKING AMPERES) 420A at  $-18^{\circ}\text{C}$  ( $0^{\circ}\text{F}$ ) and a reserve capacity 229 minutes (12V 52Ah/5HR or 12V 65Ah/20HR) or more specifications.

The battery is an optional part (i.e. part to be purchased separately from the outboard motor).

#### **▲WARNING**

**Batteries produce explosive gases: If ignited, an explosion can cause serious injury or blindness. Provide adequate ventilation when charging.**

- **CHEMICAL HAZARD: Battery electrolyte contains sulfuric acid. Contact with eyes or skin, even through clothing, may cause severe burns.**

**Wear a faceshield and protective clothing.**

- **Keep flames and sparks away, and do not smoke in the area. ANTIDOTE: If electrolyte gets into your eyes, flush thoroughly with warm water for at least 15 minutes and call a physician immediately.**

- **POISON: Electrolyte is poison.**

#### **ANTIDOTE:**

— **External: Flush thoroughly with water.**

— **Internal: Drink large quantities of water or milk. Follow with milk of magnesia or vegetable oil, and call a physician immediately.**

- **KEEP OUT OF REACH OF CHILDREN.**

To protect the battery from mechanical damage and to prevent the battery from falling or tipping over, the battery must be:

- Installed in the correct size corrosion-resistant battery box.
- Properly secured in the boat.
- Secured in a location free from direct sunlight and water spray.
- Secured away from the fuel tank to avoid potential sparks near the fuel tank.





## INSTALLATION

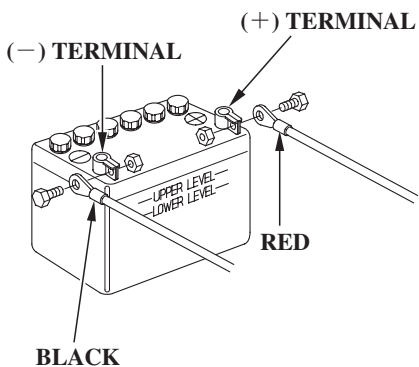

### Connect the battery cables:

1. Connect the cable with the red terminal cover to the positive (+) terminal of the battery.
2. Connect the cable with the black terminal cover to the negative (-) terminal of the battery.

### NOTE:

When the two outboard motors are mounted on a boat, connect a battery to the respective right and left outboard motors.

### NOTICE

- Be sure to connect the (+) side battery cable first. When disconnecting the cables, disconnect the (-) side first then the (+) side.
- Unless the cables are properly connected to the terminals, the starter motor may fail to operate normally.
- Be careful to avoid connecting the battery in reverse polarity, as this will damage the battery-charging system in the outboard motor.
- Do not disconnect the battery cables while the engine is running. Disconnecting the cables while the engine is running, will damage the outboard motor's electrical system.
- Do not place the fuel tank near the battery.

- **Battery cable extension:** Extending the original battery cable will cause the battery voltage to drop due to the increased length of the cable and number of connections. This voltage drop may cause the buzzer to sound momentarily when engaging the starter motor and may prevent the outboard from starting. If the outboard starts and the buzzer sounds momentarily, there may be barely sufficient voltage reaching the engine.





## INSTALLATION

### Remote Control Installation (equipped type or optional equipment)

**NOTICE**

**Improperly installed steering system, remote control box, and remote control cable, or installing those of the different types could cause unpredictable accident. Consult an authorized Honda outboard motor dealer for proper installation.**

The control box is available in three types.  
Select the most suitable control box for your outboard motor considering the installation position, operationability, etc. of the control box.  
See an authorized Honda outboard motor dealer for further information.

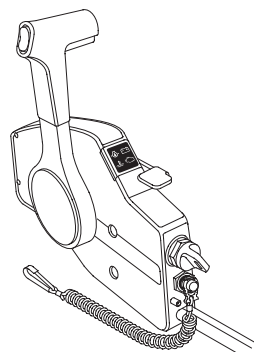

**SIDE-MOUNT TYPE REMOTE CONTROL BOX**

### 〈 Remote Control Box Location 〉

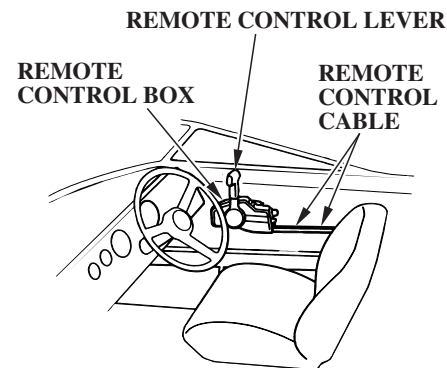

Install the remote control box in the position where is easy to operate the remote control lever and switches.  
Be sure that there are no obstacles on the route of the control cable.

The control box position of the other types should be determined in the same manner.

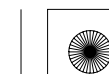





## INSTALLATION

### 〈 Remote Control Cable Length 〉

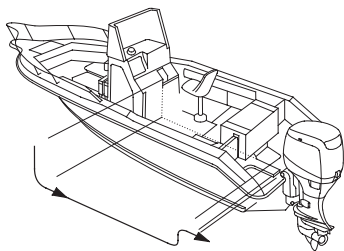

Measure the distance from the control box to the outboard motor along the cable routing. Recommended cable length is 300 – 450 mm (11.8 – 17.7 in.) longer than the measured distance. Set the cable along the pre-determined route and be sure that it is long enough to the route. Connect the cable to the engine and be sure it is not kinked, bent sharp, pulled taut, or interfered while steering.

#### NOTICE

**Do not bend the remote control cable as sharp as its route diameter is 300 mm (11.8 in.) or less, or it affects the service life of the cable and the remote control lever operation.**

### Propeller Selection

Select the adequate propeller so that the engine speed at full throttle is BF40D: 5,000 min<sup>-1</sup> (rpm) to 6,000 min<sup>-1</sup> (rpm). BF50D: 5,500 min<sup>-1</sup> (rpm) to 6,000 min<sup>-1</sup> (rpm) when the boat is loaded.

Engine speed varies according to the propeller size and the boat condition. Use of the outboard motor outside the full throttle speed range will adversely affect the engine and cause serious problem. Use of the correct propeller assures powerful acceleration, top speed, excellency in terms of economy and cruising comfort, and it assures longer engine life as well.

Consult with your authorized Honda outboard motor dealer for proper propeller selection.

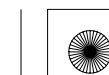



## 6. PRE-OPERATION CHECKS

BF40D/50D is 4-stroke, water cooled outboard motor which uses unleaded gasoline for fuel. It also requires the engine oil. Check the following before operating the outboard motor.

**▲ CAUTION**

**Perform the following pre-operation checks with the engine stopped.**

### Engine Cover Removal/Installation

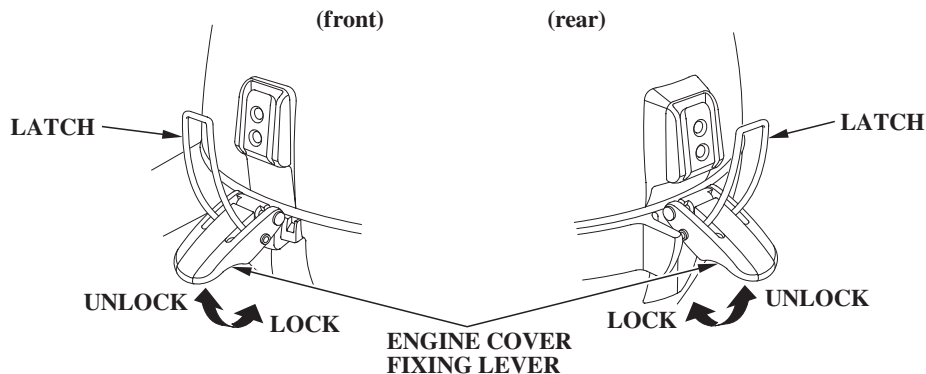

- To remove, raise the front and rear engine cover fixing levers and remove the engine cover.
- To install, set the engine cover, hook the front and rear latches, and push down the front and rear engine cover fixing levers.

**▲ WARNING**

**Do not operate the outboard motor without the engine cover. Exposed moving parts can cause injury.**

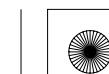



## PRE-OPERATION CHECKS

### Engine Oil

#### NOTICE

- **Engine oil is a major factor affecting engine performance and service life. Nondetergent and low quality oils are not recommended, because they have inadequate lubricating properties.**
- **Running the engine with insufficient oil can cause serious engine damage.**

#### < Recommended oil >

Use Honda 4-stroke oil or an equivalent high detergent, premium quality motor oil certified to meet or exceed U.S. automobile manufacturer's requirements for API Service category SG, SH or SJ. Motor oils classified SG, SH or SJ will show this designation on the container.

SAE 5W-30 is recommended for general use.

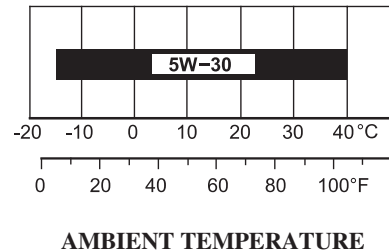

#### < Inspection and Refilling >

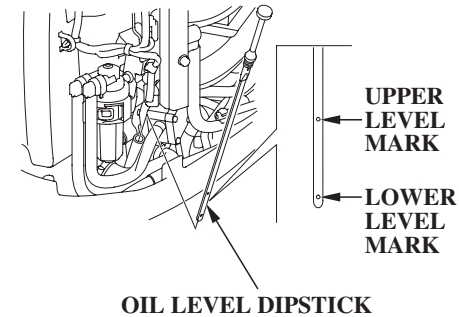

1. Position the outboard motor vertically, and remove the engine cover.
2. Remove the oil level dipstick and wipe with a clean rag.
3. Reinsert the dipstick all the way in, then pull it out and read the level. If near or below the lower level mark, remove the oil filler cap and fill to the upper level mark with the recommended oil. Tighten the oil filler cap and install the dipstick securely. Do not overtighten.





## PRE-OPERATION CHECKS

When the engine oil is contaminated or discolored, replace with the fresh engine oil (see page 111 for replacement interval and procedure).

4. Install the engine cover and lock it securely.

### NOTICE

**Do not overfill the engine oil. Check the engine oil after refilling. Excessive engine oil as well as the insufficient oil could cause damage to the engine.**

### Fuel (Fuel Tank equipped type)

FUEL GAUGE

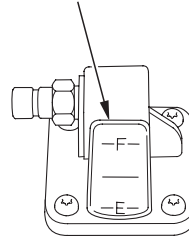

UPPER LEVEL

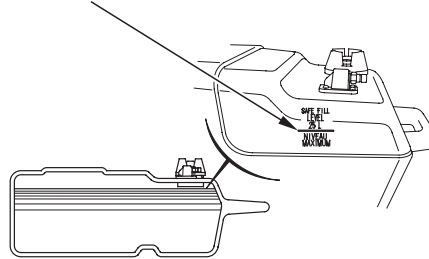

Check the fuel gauge and refill the tank to the upper level mark if necessary. Do not fill the fuel tank above the UPPER level mark.

### NOTE:

Open the vent knob before removing the fuel filler cap. When the vent knob is firmly closed, the cap will be difficult to remove.

Use unleaded gasoline with a Research Octane Number of 91 or higher (a Pump Octane Number of 86 or higher). Use of leaded gasoline may cause damage to the engine.

Never use an oil/gasoline mixture or dirty gasoline. Avoid getting dirt, dust or water in the fuel tank.

Fuel tank capacity (separate tank):  
25 L (6.6 US gal, 5.5 Imp gal)

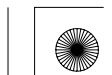



## PRE-OPERATION CHECKS

### **▲ WARNING**

**Gasoline is extremely flammable and is explosive under certain conditions.**

- **Refuel in a well-ventilated area with the engine stopped.**
  - **Do not smoke or allow flames or sparks in the area where the engine is refueled or where gasoline is stored.**
  - **Do not overfill the fuel tank (there should be no fuel in the filler neck). After refueling, make sure the fuel filler cap is closed properly and securely.**
  - **Be careful not to spill fuel when refueling. Spilled fuel or fuel vapor may ignite. If any fuel is spilled, make sure the area is dry before starting the engine.**
  - **Avoid repeated or prolonged contact with skin or breathing of vapor.**
- KEEP OUT OF REACH OF CHILDREN.**

### **GASOLINE CONTAINING ALCOHOL**

If you decide to use a gasoline containing alcohol (gasohol), be sure its octane rating is at least as high as that recommended by Honda. There are two types of “gasohol”: one containing ethanol, and the other containing methanol.

Do not use gasohol that contains more than 10% ethanol.

Do not use gasoline containing more than 5% methanol (methyl or wood alcohol) and that does not also contain co-solvents and corrosion inhibitors for methanol.

### **NOTE:**

- Fuel system damage or engine performance problems resulting from the use of gasoline that contains more alcohol than recommended is not covered under the warranty.
- Before buying gasoline from an unfamiliar station, first determine if the gasoline contains alcohol, if it does, find out the type and percentage of alcohol used. If you notice any undesirable operating symptoms while using a particular gasoline. Switch to a gasoline that you know contains less than the recommended amount of alcohol.





## PRE-OPERATION CHECKS

### Propeller and Cotter Pin Inspection

**▲WARNING**

The propeller blades are thin and sharp. Careless handling of the propeller can result in injury.

When checking the propeller:

- Remove the emergency stop switch clip to prevent an accidental start of the engine.
- Wear heavy gloves.

Propeller rotates rapidly while cruising. Before starting the engine, check the propeller blades for damage and deformation and replace if necessary.

Obtain a spare propeller for the event of an unpredictable accident while cruising. If no spare propeller is available, return to the pier at low speed and replace (see page 125 ). Consult an authorized Honda outboard motor dealer for propeller selection.

Keep the spare washer, castle nut and cotter pin with you on your boat.

54

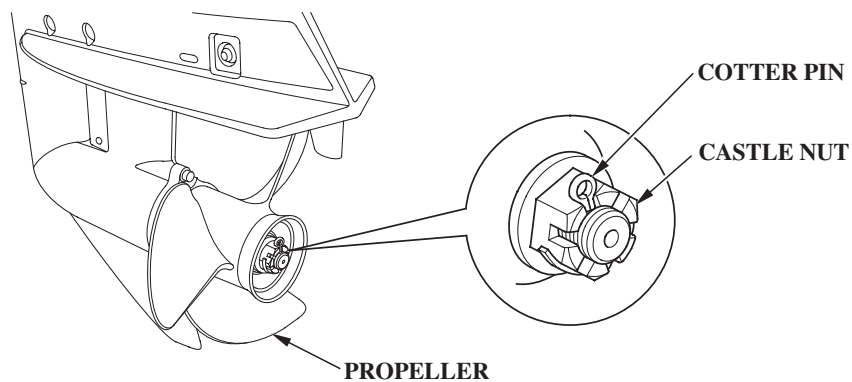

Engine speed varies according to the propeller size and the boat condition. Use of the outboard motor outside the full throttle speed range will adversely affect the engine and cause a serious problem. Use of the correct propeller assures powerful acceleration, top speed, excellency in terms of economy and cruising comfort, and it assures longer engine life as well.

Consult with your authorized Honda outboard motor dealer for proper propeller selection.

1. Check the propeller for damage, wear, or deformation. Replace whenever the propeller is faulty.
2. Check whether the propeller is installed properly.
3. Check the cotter pin for damage.

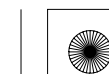



## PRE-OPERATION CHECKS

### Tiller Handle Height/Angle Adjustment (H type)

The tiller handle height and angle can be adjusted to three positions by changing the installation direction of the height adjustment block. Select a suitable height and angle for the operator and secure the block.

#### 〈 Height/Angle Adjustment Procedure 〉

1. Raise the tiller handle and remove the 8 × 28 mm flange bolt and the height adjustment block.
2. Pull down the tiller handle. Determine the height adjustment block installation direction and secure the block with the 8 × 28 mm flange bolt.

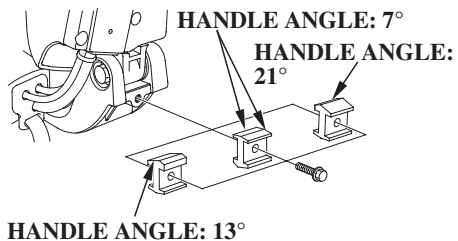

Install the height adjustment block so that the selected angle of the tiller handle is in this position.

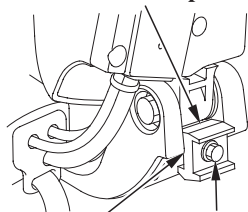

8 × 28 mm  
FLANGE BOLT

HEIGHT ADJUSTMENT  
BLOCK

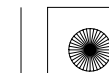
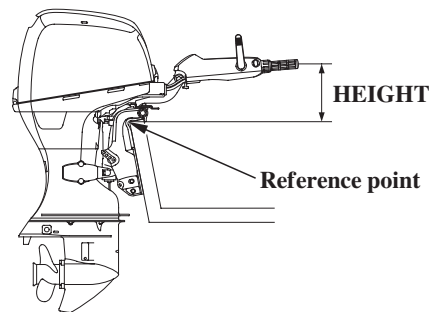
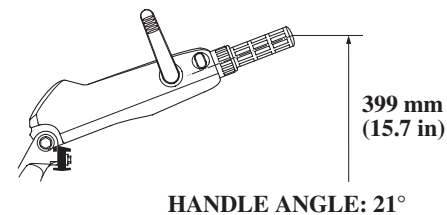



## PRE-OPERATION CHECKS

### Steering Handle Friction (H type)

STEERING FRICTION ADJUSTER  
FRICTION PLATE

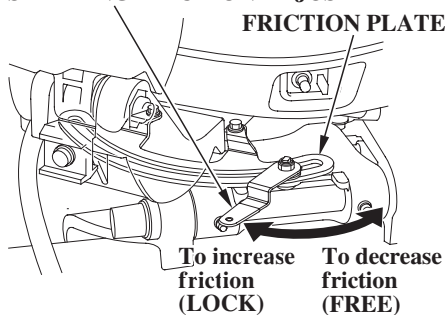

Check whether the handle moves smoothly.  
For smooth steering, adjust the steering friction adjuster so that a slight drag is felt when turning.

#### NOTE:

Do not apply grease or oil on the friction plate. Grease or oil will reduce the friction of the adjuster.

### Remote Control Lever Friction (R type)

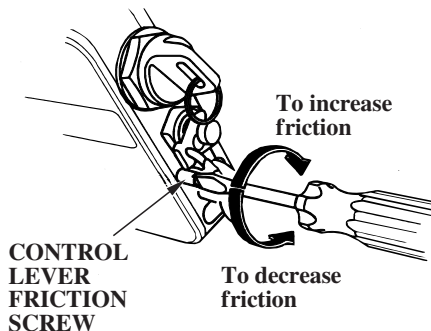

Check whether the remote control lever moves smoothly.  
Friction of the control lever can be adjusted by turning the control lever friction adjuster right or left.

### Fuel Filter

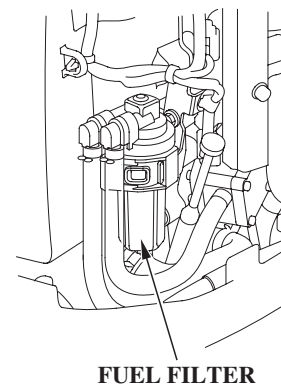

Fuel filter is located near by the engine cover fixing lever of the boat side. Check the fuel filter. When water accumulated in the fuel filter, the red ring starts to float. Clean it or consult with an authorized Honda outboard motor dealer for clean (see page 119 ).

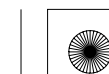





## PRE-OPERATION CHECKS

### Battery

#### NOTICE

Battery handling differs according to the type of the battery and the instructions described below might not be applicable to the battery of your outboard. Refer to the battery manufacturer's instructions.

### Battery Inspection

Check whether the battery fluid is between the upper and lower levels, and check the vent hole in the battery caps for clogging.

If the battery fluid is near or below the lower level, add the distilled water to the upper level (see page 116).

Check that the battery cables are connected securely.

If the battery terminals are contaminated or corroded, remove the battery and clean the terminals (see page 116).

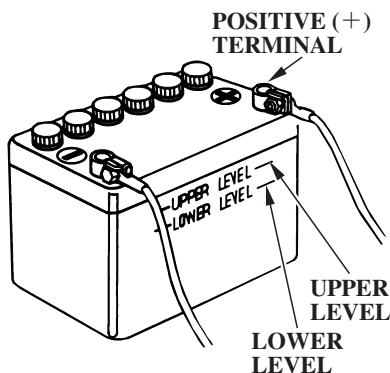

#### WARNING

**Batteries produce explosive gases: If ignited, an explosion can cause serious injury or blindness. Provide adequate ventilation when charging.**

- **CHEMICAL HAZARD: Battery electrolyte contains sulfuric acid. Contact with eyes or skin, even through clothing, may cause severe burns. Wear a faceshield and protective clothing.**

- **Keep flames and sparks away, and do not smoke in the area. ANTIDOTE: If electrolyte gets into your eyes, flush thoroughly with warm water for at least 15 minutes and call a physician immediately.**
- **POISON: Electrolyte is poison. ANTIDOTE:**
  - External: Flush thoroughly with water.
  - Internal: Drink large quantities of water or milk. Follow with milk of magnesia or vegetable oil, and call a physician immediately.
- **KEEP OUT OF REACH OF CHILDREN.**

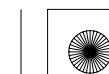



## PRE-OPERATION CHECKS

### Other Checks

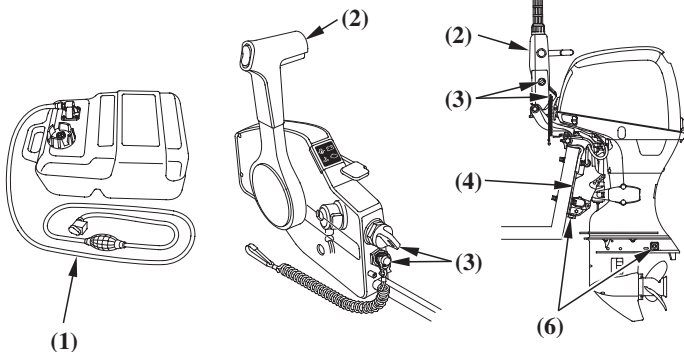

#### Check the following items:

- (1) The fuel hose for kinking, collapsing or a loose connection.
- (2) The tiller handle for loose installation, wobble or smooth operation (H type).  
The remote control lever for smooth operation (R type).
- (3) The switches for correct operation.
- (4) The stern bracket for damage or loose installation.
- (5) The tool kit for missing spare parts and tools.
- (6) The anode metal for damage, looseness or excessive corrosion.

### (5) TOOL KIT

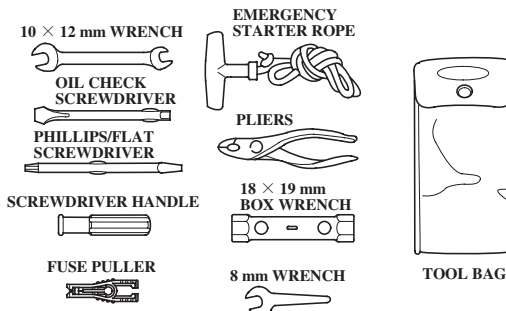

The anode (sacrificed metal) helps to protect the outboard motor from corrosion damage; it must be exposed directly to the water whenever the outboard motor is in use. Replace the anodes when they have been reduced to about two-thirds of their original size, or if they are crumbling.

#### NOTICE

**The possibility of corrosion damage is increased if the anode is painted over or allowed to deteriorate.**

Parts/materials which should be installed on board:

- (1) Owner's Manual
- (2) Tool kit
- (3) Spare parts: spark plugs, engine oil, spare propeller, castle nut, washer and cotter pin.
- (4) Spare emergency stop switch clip.
- (5) Other parts/materials required by laws/regulations.

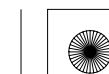



## 7. STARTING THE ENGINE

### Fuel Line Connection

**▲ CAUTION**

**Gasoline is extremely flammable, and gasoline vapor can explode, causing serious injury or death.**

- **Be careful not to spill fuel. Spilled fuel or fuel vapor may ignite. If any fuel is spilled, make sure the area is dry before starting, storing or transporting the engine.**
- **Do not smoke or allow flames or sparks where fuel is refueled or stored.**

### NOTE:

- Set the fuel tank securely so that it does not move or fall down while cruising.
- Position the fuel tank so the tank fuel line connector is no more than 1 m (3.3 feet) below the outboard motor fuel line connector.
- Do not place the fuel tank more than 2 m (6.6 feet) away from the outboard motor.
- Be sure that the fuel line is not kinked.

### (Fuel Tank equipped type)

#### FUEL LINE CONNECTOR (TO FUEL TANK)

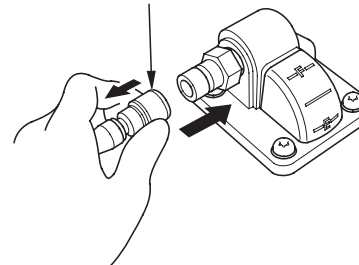

#### (FUEL TANK SIDE)

1. Connect the fuel line to the tank. Be sure the connector is securely latched.

Always disconnect the fuel line when storing or transporting the outboard motor.





## STARTING THE ENGINE

**MALE FUEL LINE CONNECTOR**  
— To outboard motor

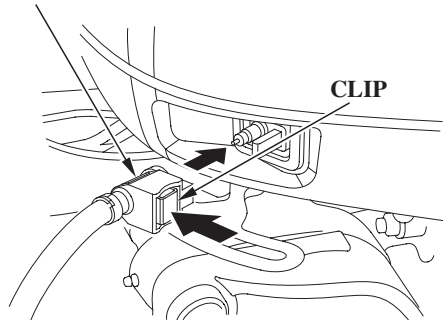

**(OUTBOARD MOTOR SIDE)**

2. Connect the fuel line connector to the outboard motor, as shown. Be sure the fuel line connector is securely snapped in place.

**NOTICE**

**If the outboard end fuel line connector is forcibly installed in the reversed direction, the fuel line connector O-ring seal can be damaged. A damaged O-ring seal can cause a fuel leak.**

**FUEL FILLER CAP VENT KNOB**

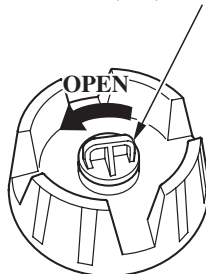

3. Turn the fuel filler cap vent knob counterclockwise all the way to open the vent.

### Fuel Priming

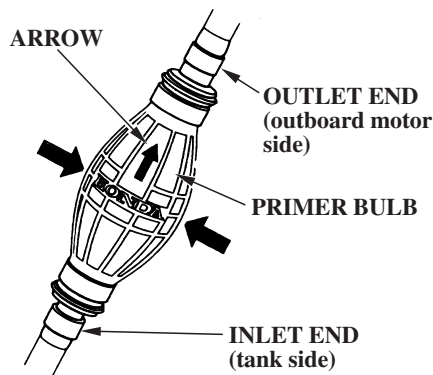

Hold the priming bulb so that the outlet end is higher than the inlet (so that the arrow on the priming bulb points up), and squeeze it until it feels firm, indicating that fuel has reached the outboard motor. Check for leaks.

**▲ WARNING**

**Be careful not to spill any fuel. Spilled fuel vapor may ignite. If any fuel is spilled, make sure the area is dry before starting the engine.**





## STARTING THE ENGINE

### NOTICE

Do not touch the priming bulb with the engine running or when tilting up the outboard motor. The vapor separator could overflow.

### Starting the Engine (H type)

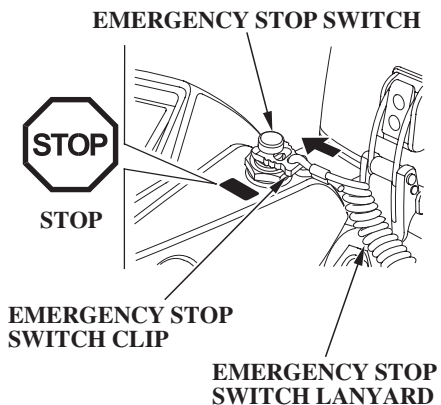

### ▲WARNING

The exhaust contains poisonous carbon monoxide. Do not start the engine in a poor ventilation area such as in a boat house.

### NOTICE

To prevent damage to the outboard from overheating, never run the engine with the propeller out of water.

1. Insert the emergency stop switch clip at one end of the emergency stop switch lanyard into the emergency stop switch. Attach the other end of the lanyard securely to the operator.

### ▲WARNING

If the operator does not attach the emergency stop switch lanyard, and is thrown from his seat or out of the boat, the out-of-control boat can seriously injure the operator, passengers, or bystanders. Always properly attach the lanyard before starting the engine.

### NOTE:

The engine will not start unless the emergency stop switch clip is engaged with the emergency stop switch.

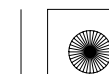



## STARTING THE ENGINE

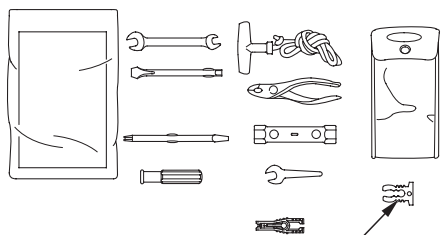

**SPARE EMERGENCY STOP SWITCH CLIP**

Store the spare emergency stop switch clip in the tool bag. Use the spare emergency stop switch clip to make the disabled engine start when the emergency stop switch lanyard is not available as, for example, when the operator falls overboard.

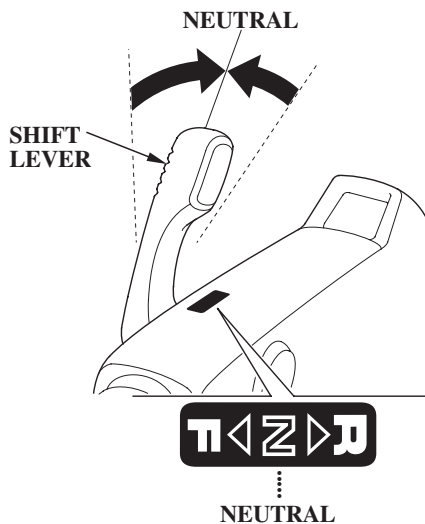

2. Move the shift lever to the NEUTRAL position. The engine does not start unless the shift lever is set in the NEUTRAL position.

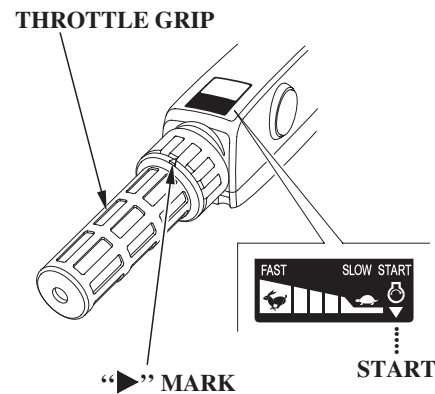

3. Align the “ ⚙ ” mark on the throttle grip with the projected end of the “ ▶ ” mark on the handle.

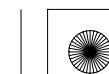



## STARTING THE ENGINE

ENGINE SWITCH KEY

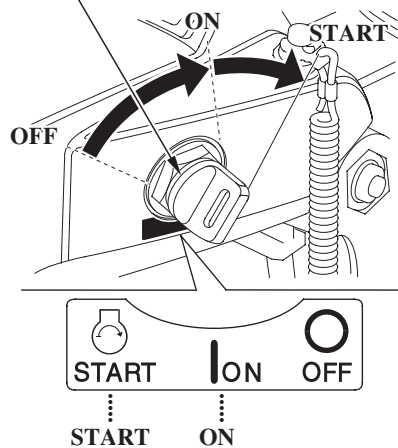

- Turn the engine switch key to the START position and hold it there until the engine starts. When the engine starts, release the key, allowing it to return to the ON position.

### NOTICE

- The starter motor consumes a large amount of current. Do not therefore run it continuously for more than 5 seconds at a time. If the engine does not start within 5 seconds, wait at least 10 seconds before running the starter motor again.
- Do not turn the engine switch key to the START position while the engine is running.

### NOTE:

The “Neutral Starting System” prevents the engine from being started unless the control lever is set in the N (neutral) position even though the engine is cranked by the starting engine.

COOLING WATER CHECK HOLE

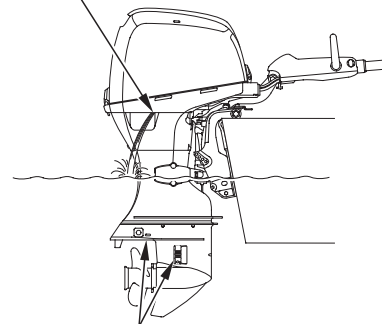

COOLING WATER INTAKE PORT

- After starting, check whether the cooling water is flowing out of the cooling water check hole. Amount of water flowing out of the check hole might vary due to the thermostat operation, but this is normal.

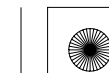



## STARTING THE ENGINE

### NOTICE

If water does not flow out, or if steam comes out, stop the engine. Check to see if the screen in the cooling water intake port is obstructed and remove foreign materials if necessary. Check the cooling water check hole for clogging. If water still does not flow out, have your outboard motor checked by an authorized Honda outboard motor dealer. Do not operate the engine until the problem has been corrected.

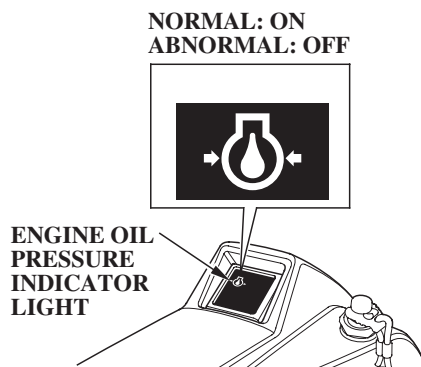

6. Check to see if the oil pressure indicator light turns ON. If it does not turn on, stop the engine and perform the following inspections.
  - 1) Check the oil level (see page 51 ).
  - 2) If the oil level is normal and the oil pressure indicator light does not turn ON, consult with an authorized Honda outboard motor dealer.
7. Warm up the engine as follows:  
Above 5°C (41°F)—run the engine

for at least 3 minutes.  
Below 5°C (41°F)—run the engine for at least 5 minutes at approx. 2,000 min<sup>-1</sup> (rpm).  
Failure to completely warm up the engine will result in poor engine performance.

### NOTICE

- If the engine is not properly warmed-up before raising the engine speed, the warning buzzer and overheat indicator may activate and the engine speed will be automatically reduced.
- The cooling system may freeze in areas where the temperature reaches 0°C (32°F) or below. Cruising at high speed without warming the engine up may cause engine damage.

### NOTE:

Before leaving the dock, check the operation of the emergency stop switch.

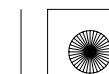





## STARTING THE ENGINE

### Starting the Engine (R type)

(R1 type)

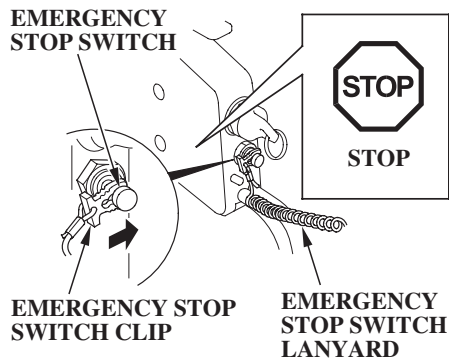

**▲WARNING**

The exhaust contains poisonous carbon monoxide. Do not start the engine in a poor ventilation area such as in a boat house.

**NOTICE**

To prevent damage to the outboard from overheating, never run the engine with the propeller out of water.

1. Insert the emergency stop switch clip at one end of the emergency stop switch lanyard into the emergency stop switch. Attach the other end of the emergency stop switch lanyard securely to the operator.

**▲WARNING**

If the operator does not attach the emergency stop switch lanyard, and is thrown from his seat or out of the boat, the out-of-control boat can seriously injure the operator, passengers, or bystanders. Always properly attach the lanyard before starting the engine.

**NOTE:**

The engine will not start unless the emergency stop switch clip is engaged with the emergency stop switch.

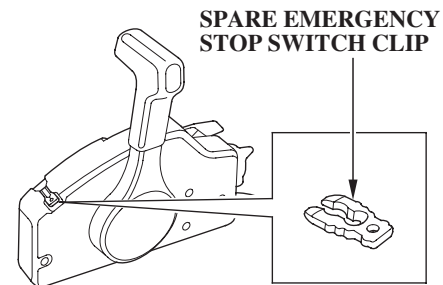

A spare emergency stop switch clips is provided on the remote control box.

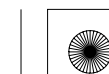



## STARTING THE ENGINE

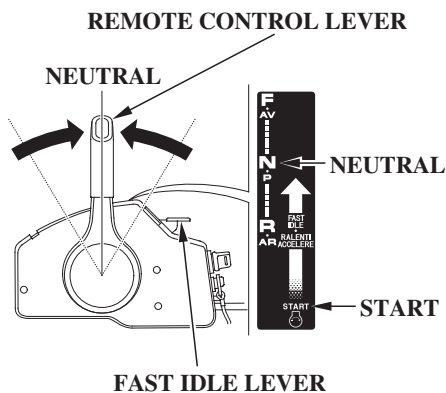

2. Set the remote control lever in the NEUTRAL position.  
The engine does not start unless the remote control lever is set in the NEUTRAL position.
3. Leave the fast idle lever in the START (fully lowered) position.

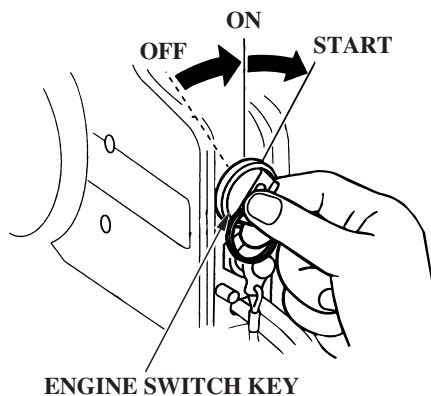

4. Turn the engine switch key to the START position and hold it there until the engine starts.  
When the engine starts, release the key, allowing it to return to the ON position.

### NOTICE

- The starter motor consumes a large amount of current. Do not therefore run it continuously for more than 5 seconds at a time. If the engine does not start within 5 seconds, wait at least 10 seconds before running the starter motor again.
- Do not turn the engine switch key to the START position while the engine is running.

### NOTE:

The “Neutral Starting System” prevents the engine from being started unless the control lever is set in the N (neutral) position even though the engine is cranked by the starting engine.

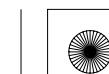



## STARTING THE ENGINE

COOLING WATER  
CHECK HOLE

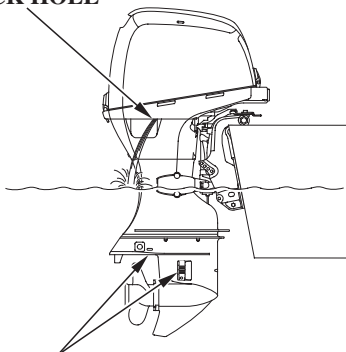

COOLING WATER INTAKE PORT

5. After starting, check whether the cooling water is flowing out of the cooling water check hole. Amount of water flowing out of the check hole might vary due to the thermostat operation, but this is normal.

### NOTICE

If water does not flow out, or if steam comes out, stop the engine. Check to see if the screen in the cooling water intake port is obstructed and remove foreign materials if necessary. Check the cooling water check hole for clogging. If water still does not flow out, have your outboard motor checked by an authorized Honda outboard motor dealer. Do not operate the engine until the problem has been corrected.

6. Check to see if the oil pressure indicator turns ON.

If it does not turn on, stop the engine and perform the following inspections.

- 1) Check the oil level (see page 51).
- 2) If the oil level is normal and the oil pressure indicator light does not turn ON, consult with an authorized Honda outboard motor dealer.

ENGINE OIL PRESSURE  
INDICATOR LIGHT

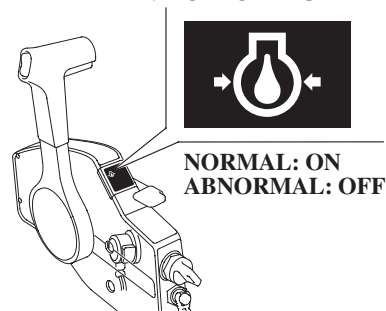

NORMAL: ON  
ABNORMAL: OFF

Digital Tachometer

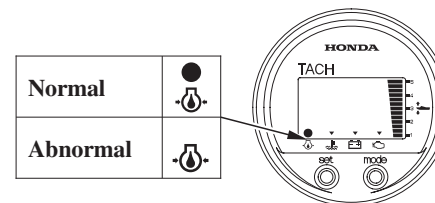

Normal



Abnormal

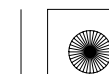



## STARTING THE ENGINE

7. Warm up the engine as follows:  
Above 5°C (41°F) — run the engine for at least 3 minutes.  
Below 5°C (41°F) — run the engine for at least 5 minutes at approx. 2,000 min<sup>-1</sup> (rpm).  
Failure to completely warm up the engine will result in poor engine performance.

### NOTICE

- If the engine is not properly warmed-up before raising the engine speed, the warning buzzer and overheat indicator may activate and the engine speed will be automatically reduced.
- The cooling system may freeze in areas where the temperature reaches 0°C (32°F) or below. Cruising at high speed without warming the engine up may cause engine damage.

### NOTE:

Before leaving the dock, check the operation of the emergency stop switch.

68

### Emergency Starting

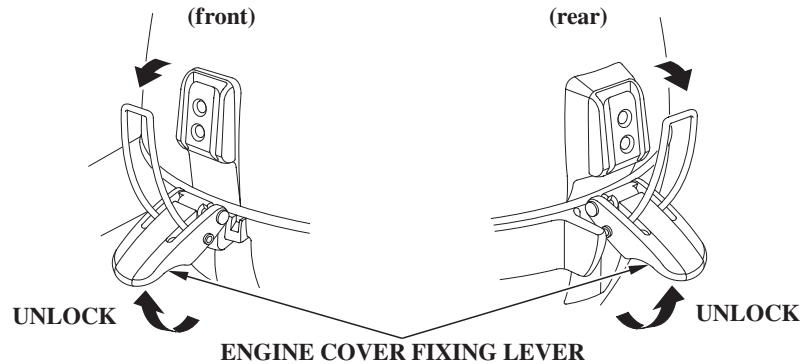

If the starting system does not operate properly for some reasons, the engine can be started using the emergency starter rope in the tool kit.

1. Turn the engine switch key to the OFF position.
2. Raise the front and rear fixing levers, and remove the engine cover.

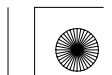



## STARTING THE ENGINE

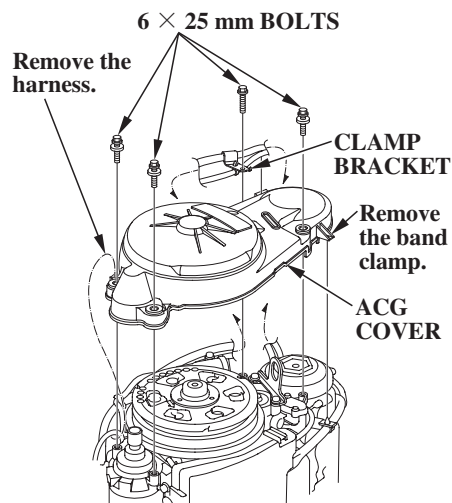

3. Remove the four 6 × 25 mm bolts and clamp bracket, then remove the ACG cover.
4. Install the band clamp, harness and the clamp bracket with the 6 × 25 mm bolt.

**NOTE:**

Take care not to lose the bolts.

(H type)

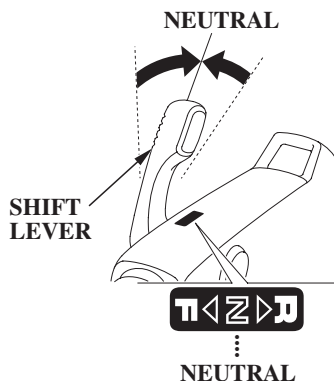

(R1 type)

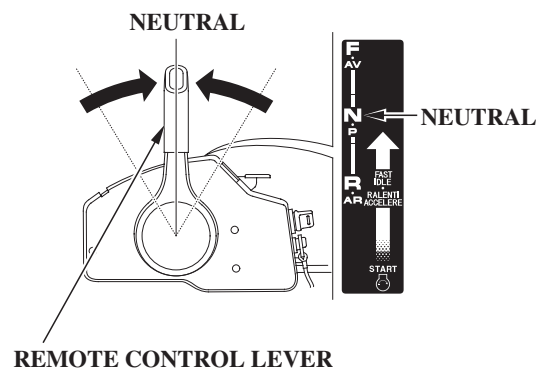

5. Set the shift lever or remote control lever is in the NEUTRAL position.

**▲WARNING**

The “Neutral Starting System” will not work in emergency starting. Be sure to set the shift lever/control lever into the NEUTRAL position to prevent start-in-gear when starting the engine in emergency. Sudden unexpected acceleration could result in serious injury or death.

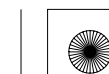



## STARTING THE ENGINE

(H type)

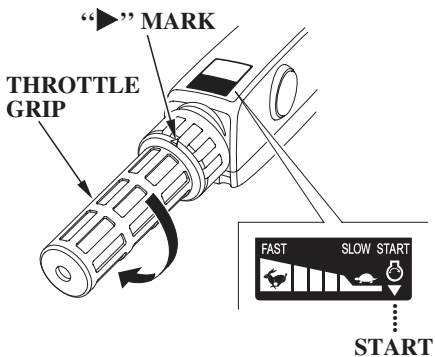

(R1 type)

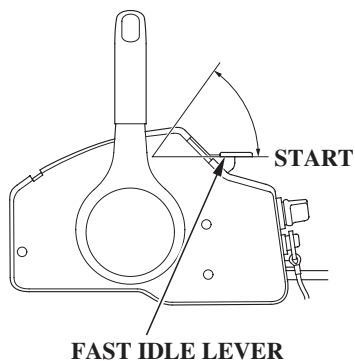

6. H type:

Align the “⊗” (start mark) on the throttle grip with the projected end of the “▶” mark on the tiller handle.

R1 type:

Leave the fast idle lever in the START (fully lowered) position.

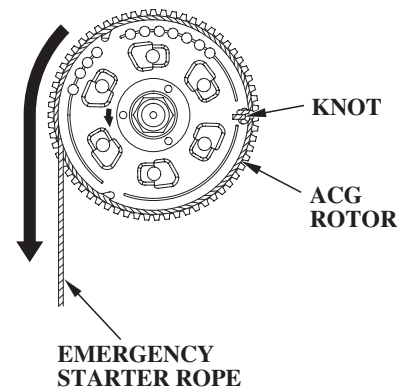

7. Set the ACG rotor so the cutouts are on the right and left sides of the ACG rotor as shown. Hook the knot at the end of the starter rope (accessory) against a cutout in the ACG rotor and wind the starter rope one and half turns counterclockwise along the groove in the ACG rotor.

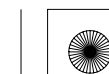



## STARTING THE ENGINE

(H type)

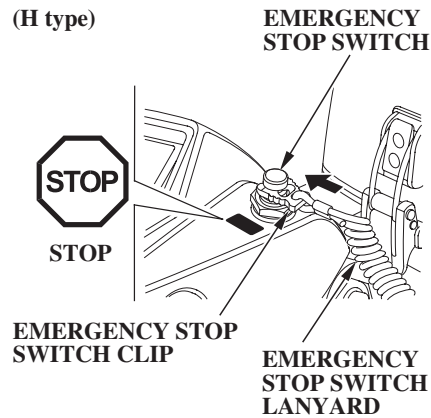

(R1 type)

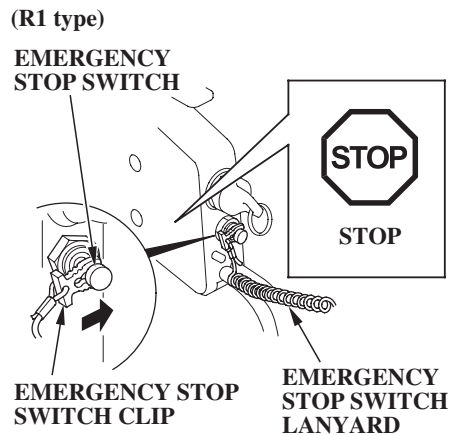

SPARE EMERGENCY STOP SWITCH CLIP

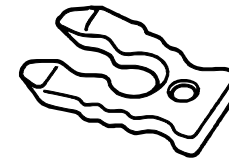

8. Insert the emergency stop switch clip at the end of the emergency stop switch lanyard into the emergency stop switch. Attach the other end of the emergency stop switch lanyard securely to the operator.

**NOTE:**

The engine does not start unless the emergency stop switch clip is set on the emergency stop switch.

A spare emergency stop switch clip is provided;

R1 type: on the remote control box (see page 28 ).

H type: store the clip in the tool bag.





## STARTING THE ENGINE

(H type)

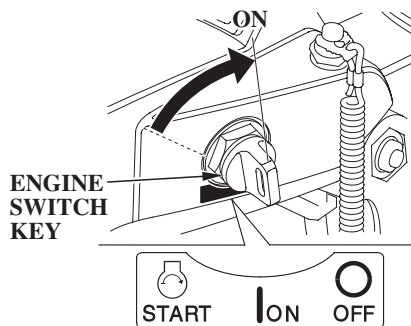

9. Turn the engine switch key to the ON position.

**NOTICE**

**The propeller must be lowered into the water, running the outboard motor out of the water will damage the water pump and overheat the engine.**

(R1 type)

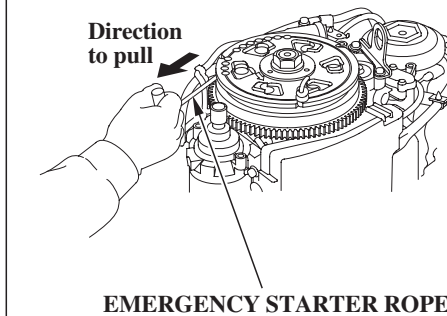
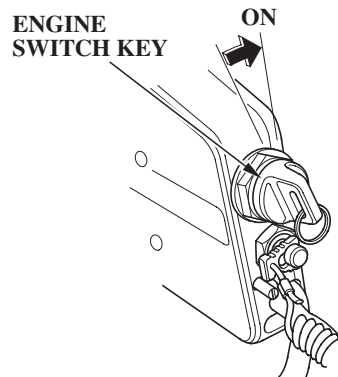

10. Pull the emergency starter rope lightly until resistance is felt, then pull briskly in the direction of the arrow as shown above.

If the engine fails to start refer to Troubleshooting page 135.

**▲WARNING**

**Exposed moving parts can cause injury. Use extreme care when installing the engine cover. Do not operate the outboard motor without the engine cover.**

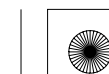





## STARTING THE ENGINE

---

11. Leave the ACG cover off and install the engine cover. Lock the engine cover fixing levers.
12. Attach the emergency stop switch lanyard securely to the operator and return to the closest boat landing.
13. After returning to the closest boat landing, contact your closest authorized Honda outboard motor dealer and perform the following.
  - Have the electrical system checked.
  - Have your dealer reassemble the parts removed in the emergency starting procedure.

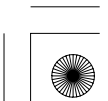
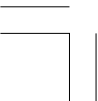



## 8. OPERATION

---

### Break-in Procedure

Break-in period: 10 hours

Break-in operation allows the mating surfaces of the moving parts to wear evenly and thus ensures proper performance and longer outboard motor life.

Break-in your new outboard motor as follows.

First 15 minutes:

Run the outboard motor at trolling speed. Use the minimum amount of throttle opening necessary to operate the boat at a safe trolling speed.

Next 45 minutes:

Run the outboard motor up to a maximum of 2,000 to 3,000  $\text{min}^{-1}$  (rpm) or 10% to 30% throttle opening.

Next 60 minutes:

Run the outboard motor up to maximum of 4,000 to 5,000  $\text{min}^{-1}$  (rpm) or 50% to 80% throttle opening. Short bursts of full throttle are acceptable but do not operate the outboard motor continuously at full throttle.

Next 8 hours:

Avoid continuous full throttle operation (100% throttle opening). Do not run the outboard motor at full throttle for more than 5 minutes at a time.

For boats that plane easily, bring the boat up on plane then reduce the throttle opening to the specified break-in settings called out above.

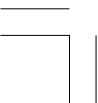



## OPERATION

### Gear Shifting (H type)

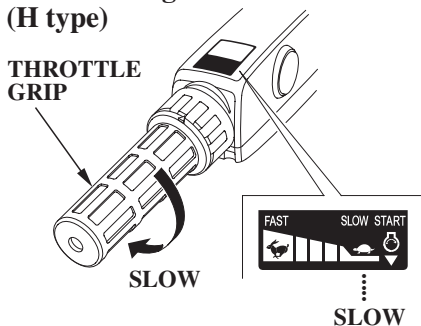

The shift lever has 3 positions:  
FORWARD, NEUTRAL, and  
REVERSE.

An indicator at the base of the shift  
lever aligns with the icon attached at  
the tiller handle.

#### **▲CAUTION**

**Be sure to perform the gearshift  
operation at a low engine speed.  
Shifting the gear at a high  
engine speed will damage the  
drive system. Be sure that the  
gear was shifted securely, then  
operate the throttle grip to raise  
the engine speed.**

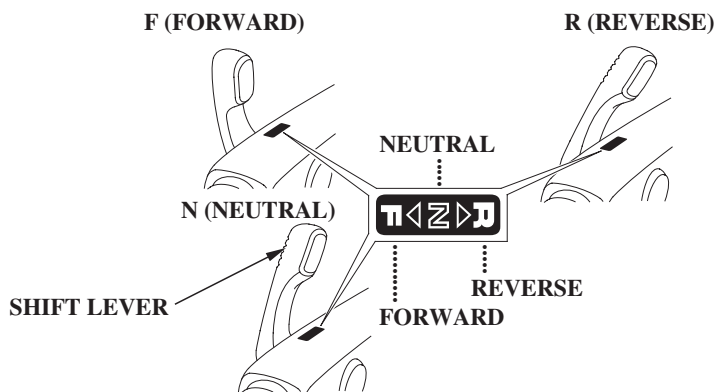

1. Align the pointer on the tiller  
handle with the SLOW position on  
the throttle grip to decrease engine  
speed.

#### **NOTE:**

The throttle mechanism is designed  
to limit throttle opening in  
REVERSE and NEUTRAL. Do not  
turn the throttle grip with force in the  
FAST direction. The throttle can be  
opened to FAST only in FORWARD  
gear.

Be sure that the tilt lever is in the  
LOCK position. (G type)

2. Move the shift lever to engage the  
desired gear.

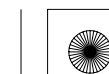



## OPERATION

### Steering (H type)

**RIGHT TURN**



Move the tiller handle to the left.

**LEFT TURN**



Move the tiller handle to the right.

Steer by moving the tiller handle opposite the direction you want the boat to turn.

### STEERING FRICTION ADJUSTER

#### FRICTION PLATE

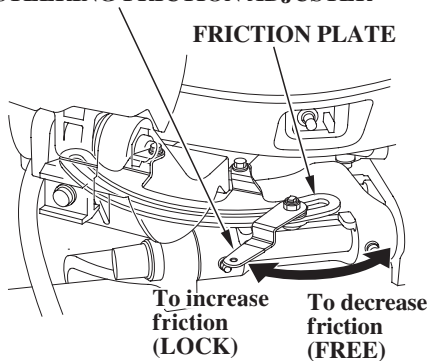

Use the steering friction adjuster to help hold a steady course while cruising.

Move the adjuster to the LOCK direction to increase steering friction for holding a steady course.

Move the adjuster to the FREE direction to decrease friction for easy turning.

### NOTE:

Do not apply grease or oil on the friction plate. Grease or oil will reduce the friction of the adjuster.

### (R type)

Steer the boat in the same manner as an automobile.

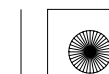



## OPERATION

### Cruising (H type)

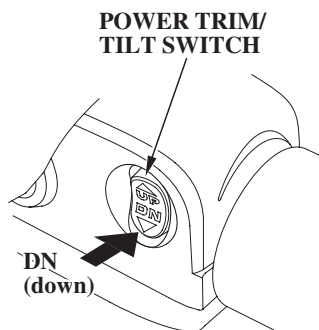

1. On the T type, press the DN (down) portion of the power trim/tilt switch and trim the outboard motor to the lowermost position.

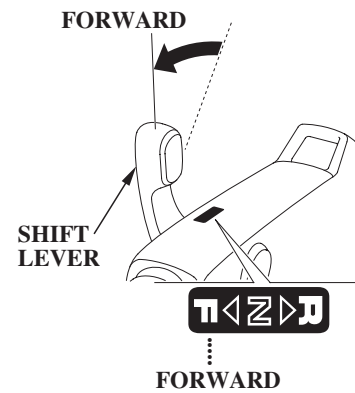
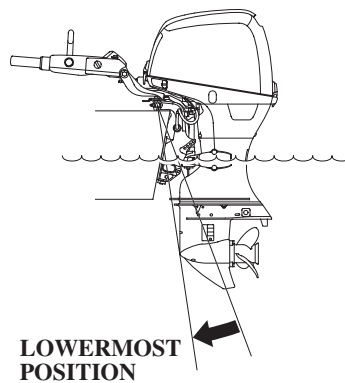

2. With the shift lever in the FORWARD position.





## OPERATION

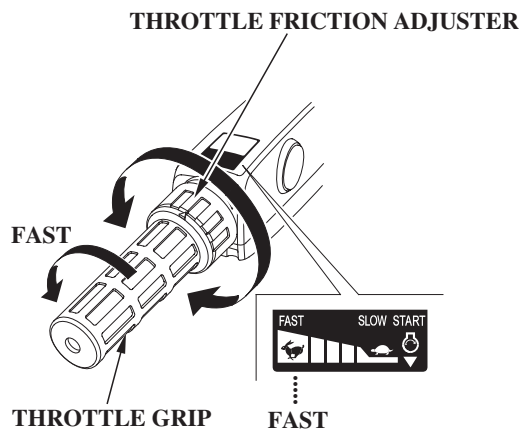

3. Turn the throttle grip in the FAST direction to increase the speed. For the sake of fuel economy, open the throttle about 80%.

To hold the throttle at a steady setting, turn the throttle friction adjuster clockwise. To free the throttle grip for manual speed control, turn the friction adjuster counterclockwise.

### NOTE:

- When cruising at full throttle, note that the engine speed must be in the range BF40D: between 5,000 min<sup>-1</sup> (rpm) and 6,000 min<sup>-1</sup> (rpm), BF50D: between 5,500 min<sup>-1</sup> (rpm) and 6,000 min<sup>-1</sup> (rpm).
- If you feel that the engine speed jumped up when the hull jumped or at ventilation, cruise the boat by returning the throttle to the slow speed side.
- See “Propeller Selection” (page 49 ) for a relation between the propeller and the engine speed.

### ▲ CAUTION

**Do not operate without the engine cover. Exposed moving parts could cause injury; water may damage the engine.**

### NOTE:

For best performance, passengers and equipment should be distributed evenly to balance the boat.





## OPERATION

### Trimming the Outboard Motor

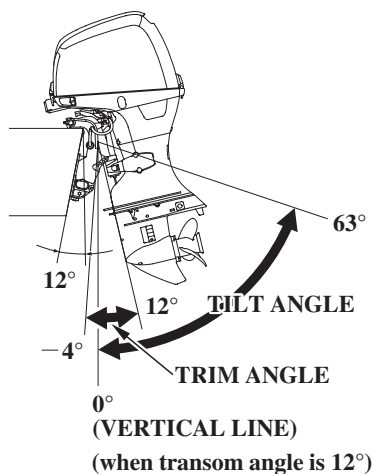

The BF40D/50D T types are equipped with the power trim/tilt system which can adjust the outboard motor angle (trim/tilt angle) while cruising and mooring. The outboard motor angle can also be adjusted while cruising and accelerating to obtain the maximum speed and optimum driveability and fuel economy.

(H type)

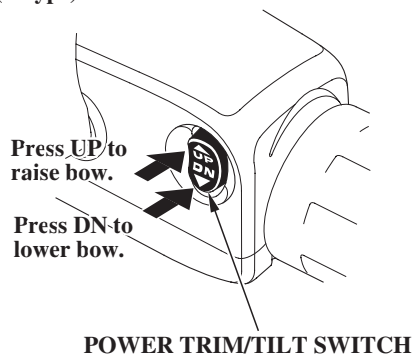

Press either UP or DN (down) of the power trim/tilt switch and tilt the outboard motor to the best position in compliance with the cruising conditions.

(R1 type)

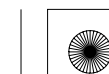
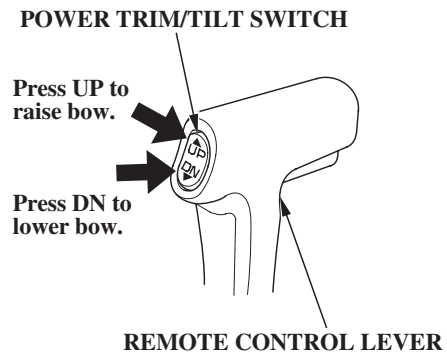



## OPERATION

---

The power trim/tilt system operates when the switch is pressed, and it stops when the switch is released. To trim up slightly, press on UP momentarily but securely. To trim down slightly, press on DN (down) in the same manner.

### **▲ CAUTION**

- **Improper trim angle results in unstable steering condition.**
- **Do not trim excessively while cruising through rough waves, or it may cause an accident.**
- **Excessive trim angle can result in cavitation and racing of the propeller, and trimming up the outboard motor excessively can cause damage to the water pump.**

### **NOTE:**

- Decrease the trim angle on high speed turns to reduce the possibility of propeller ventilation.
- Improper outboard motor trim angle can result in an unstable steering condition.







## OPERATION

### Gear Shifting (R type) (R1 type)

REMOTE CONTROL  
LEVER

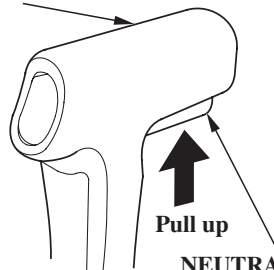

NEUTRAL RELEASE  
LEVER

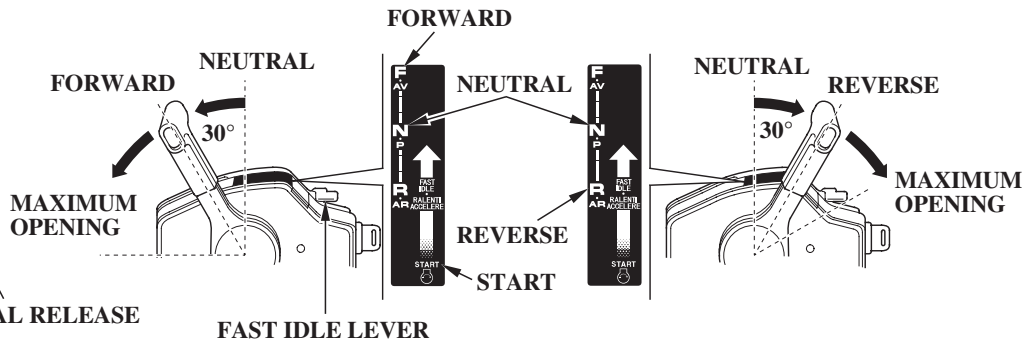

#### ▲CAUTION

**Avoid sharp and abrupt operation of the remote control lever. Operate it moderately. Operate the remote control lever and raise the engine speed after making sure that the gear was shifted securely.**

Be sure that the tilt lever is in the LOCK position. (G type)

While pulling the neutral release lever, move the remote control lever approximately 30° toward the FORWARD or REVERSE position to engage the desired gear. Moving the remote control lever further from approximately 30° will increase throttle opening and boat speed.

The remote control lever will not move unless the neutral release lever is pulled up.





## OPERATION

### Cruising (R type) (R1 type)

#### POWER TRIM/TILT SWITCH

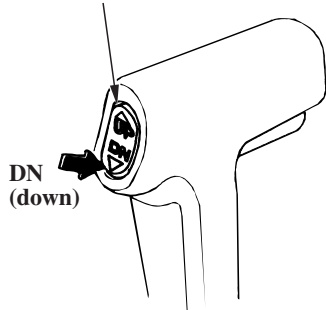

1. On the T type, press the DN (down) of the power trim/tilt switch and trim the outboard motor at the lowermost position.

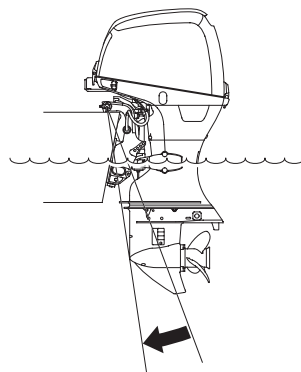

LOWERMOST POSITION

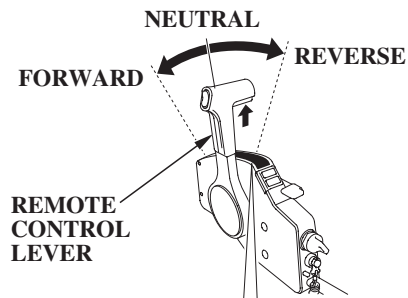

FORWARD

2. Move the remote control lever from NEUTRAL toward FORWARD position.

Moving about 30° engages the gear. Moving the remote control lever further opens the throttle and increases the engine speed.

For the sake of fuel economy, open the throttle about 80%.

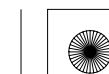



## OPERATION

**OUTBOARD MOTOR TRIMMED TOO LOW**

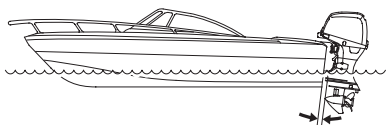

**OUTBOARD MOTOR TRIMMED TOO HIGH**

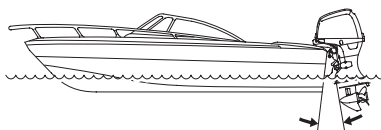

**OUTBOARD MOTOR TRIMMED CORRECTLY**

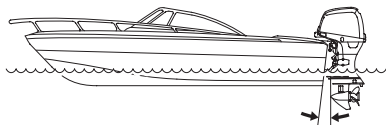

**When cruising:**

- (A) Into a high wind, trim the outboard motor down slightly to lower the bow and improve boat stability.
- (B) With a tail wind, trim the outboard motor up slightly to raise the bow and improve boat stability.
- (C) Through rough waves, do not trim the outboard motor too low or too high to avoid an unstable steering condition.

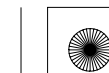



## OPERATION

### Trim Meter (equipped type or optional equipment)

The trim meter indicates the trim angle of the outboard motor. Refer to the trim meter, and press the UP or DN (down) portion of the power trim/tilt switch to adjust the outboard motor trim angle to achieve boat performance and stability.

The illustration represents R1 type. Perform the same procedure for the other types.

#### BOW TOO LOW DUE TO

1. LOAD IN THE FRONT
2. OUTBOARD MOTOR TRIMMED TOO LOW

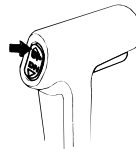
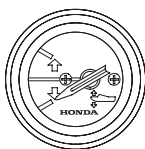
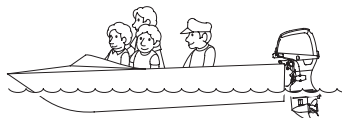

#### Digital Tachometer

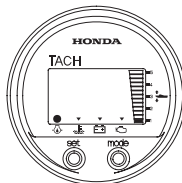

With the outboard motor trimmed low the trim meter will read as shown. To raise the bow increase the outboard motor trim angle by pressing the UP portion of the power trim/tilt switch.

#### BOW TOO HIGH DUE TO

1. LOAD IN THE REAR
2. OUTBOARD MOTOR TRIMMED TOO HIGH

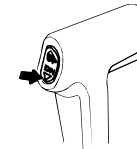
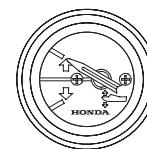
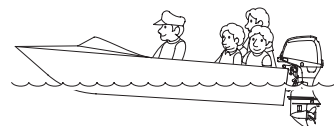

#### Digital Tachometer

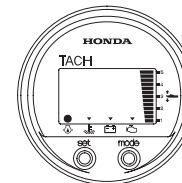

With the outboard motor trimmed high the trim meter will read as shown. To lower the bow decrease the outboard motor trim angle by pressing the DN (down) portion of the power trim/tilt switch.





## OPERATION

### Tilting the Outboard Motor (T type)

Tilt the outboard motor to prevent the propeller and gear case from hitting the bottom when the boat is beached or stopped in shallow water. Please tilt up simultaneously, when you mount the dual type outboard motor.

1. Move the shift lever or the remote control lever to the NEUTRAL position and stop the engine.
2. Press the UP of the power trim/tilt switch and tilt the outboard motor to the best position in compliance.

(H type)

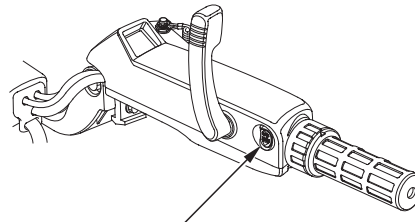

POWER TRIM/TILT SWITCH

(R1 type)

POWER TRIM/TILT SWITCH

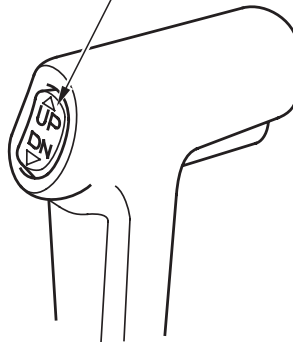

### Tilting the Outboard Motor (G type)

Tilt the outboard motor to prevent the propeller and gear case from hitting the bottom when the boat is beached or stopped in shallow water.

1. Move the shift lever or the remote control lever to the NEUTRAL position and stop the engine.

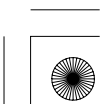
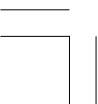



## OPERATION

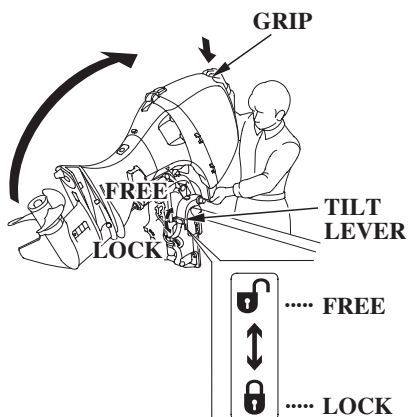

2. Move the tilt lever to the FREE position. Hold the engine cover grip and raise the outboard motor. (The outboard motor can be tilted stagelessly.)

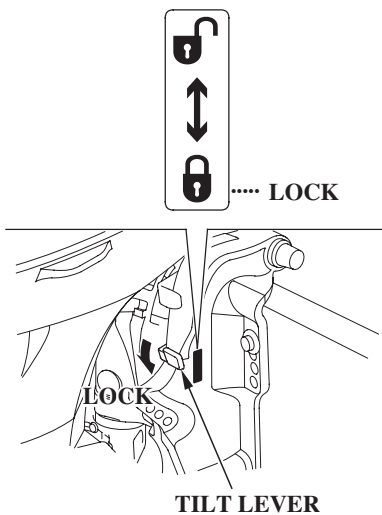

3. With the outboard motor tilted up at the designated position, move the tilt lever to the LOCK position to lock the outboard motor in the position.



4. To return the outboard motor, move the tilt lever to the FREE position, tilt up the outboard motor slightly by holding the engine cover grip, and lower the engine gently to the designated position.

**▲ CAUTION**

**Set the tilt lever in the FREE/ LOCK positions securely.**

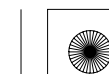



## OPERATION

### Moorage

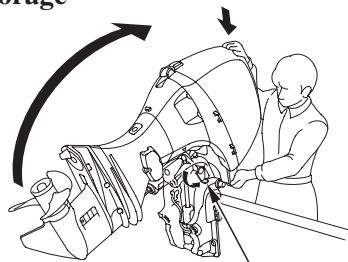

**TILT LOCK LEVER**

Tilt up the outboard motor using the tilt lock lever when mooring the boat. Shift the shift lever or the remote control lever into the NEUTRAL position and stop the engine before tilting up the outboard motor.

#### NOTE:

Before tilting up, leave the outboard motor in the running position for one minute after stopping the engine to drain the water from inside the engine.

Stop the engine and disconnect the fuel line from the outboard motor before tilting the outboard motor.

### TILT LOCK LEVER

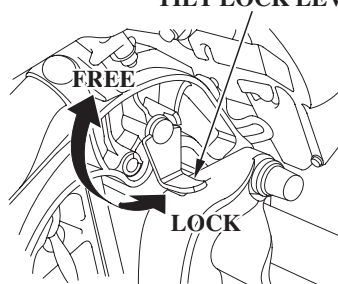

### T type

1. Raise the outboard motor as full as it goes using the power trim/tilt switch.
2. Move the tilt lock lever to the LOCK position and lower the outboard motor until the lock lever contacts the stern bracket.
3. To tilt down, raise the outboard motor as far as it goes using the power trim/tilt switch, move the tilt lock lever to the FREE position.

### G type

1. Move the tilt lever to the FREE position and raise the outboard motor as far as it goes by holding it by the grip of the engine cover.
2. Move the tilt lock lever to the LOCK position and lower the outboard motor slowly.
3. Move the tilt lever to the LOCK position.
4. To tilt down, move the tilt lever to the FREE position, and move the tilt lock lever to the FREE position while lifting the outboard motor to the designated position and move the tilt lever to the LOCK position.





## OPERATION

### Manual Relief Valve

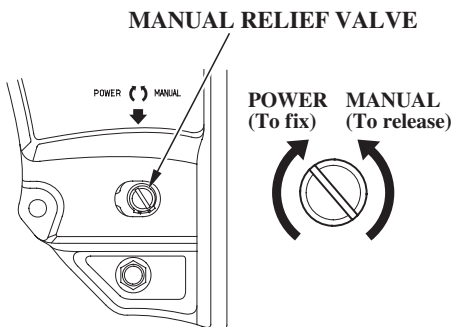

When power trim/tilt system does not operate because of dead battery or faulty power trim/tilt motor, the outboard motor can be manually tilted up or down by operating the manual relief valve.

To tilt the outboard motor manually, turn the manual relief valve under the stern bracket two and a half turns counterclockwise using a screwdriver.

#### NOTICE

**Do not loosen the manual relief valve more than two and a half turns, or the outboard motor cannot be tilted up when the manual relief valve is retightened.**

After tilting up/down manually, close the manual relief valve to lock the outboard motor in the position.

Check that nobody is under the outboard motor before opening the manual relief valve. If the manual relief valve is loosened (turned counterclockwise) when the outboard motor is tilted up, the outboard motor will suddenly tilt down.

#### CAUTION

**The manual relief valve must be tightened securely before operating the outboard motor or the outboard motor could tilt when operating in reverse.**

### Power Tilt Switch (T type)

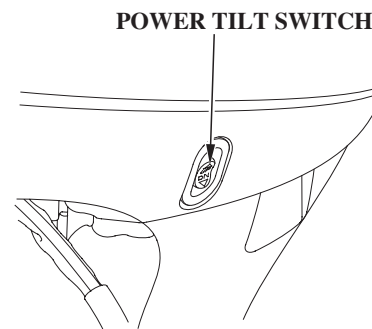

When you are away from the power trim/tilt switch on the control lever side, you can operate the power tilt switch on the outboard motor side. The switch operation is the same as that of the power trim/tilt switch on the control lever side.

#### CAUTION

**Do not operate this power tilt switch on the outboard motor while sailing.**







## OPERATION

### Trim Tab Adjustment

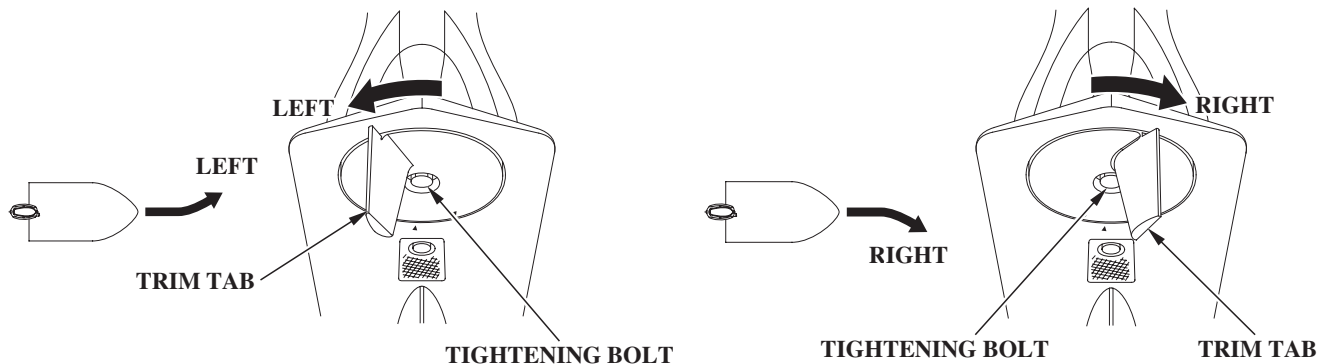

The trim tab is provided to adjust for “torque steer” which is a reaction of the propeller rotation or propeller torque. If during a high speed turn an unequal amount of effort is required to turn the boat right or left, adjust the trim tab so that an equal amount of effort is required.

Distribute the load evenly in the boat and run the boat in a straight course at full throttle. Slightly turn the steering wheel/handle for both right and left turns to determine the amount of effort required.

Loosen the tightening bolt to adjust the trim tab.

If less effort is required to make left turns:

Loosen the trim tab tightening bolt and turn the rear end of the trim tab toward the left. Tighten the bolt securely.

If less effort is required to make right turns:

Loosen the trim tab tightening bolt and turn the rear end of the trim tab toward the right. Tighten the bolt securely.

Make small adjustments at a time and retest. Incorrect trim tab adjustment can cause adverse steering.





## OPERATION

### Engine Protection System 〈Engine Oil Pressure, Overheat, PGM-FI and ACG Warning Systems〉

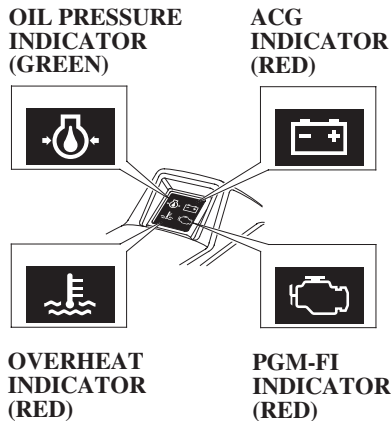

(internal buzzer)

(H type)

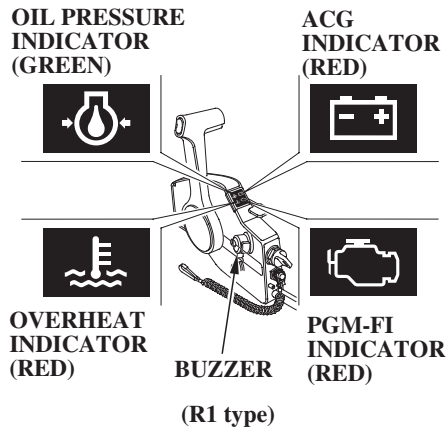

DIGITAL TACHOMETER (R type)

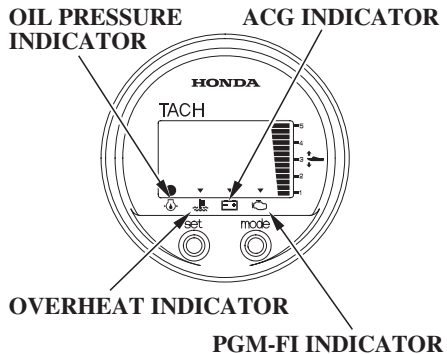

If the engine oil pressure drops and/or the engine overheats, either or both warning systems could be activated.

When activated the engine speed will decrease gradually and the oil pressure indicator will turn OFF and the overheat indicator will turn ON. A continuous buzzer will sound on all type.

The engine speed can not be increased with a larger throttle opening until the malfunction is corrected.

When the malfunction is corrected the engine speed will increase gradually.

If the engine overheats, the engine will stop in 20 seconds after the engine protection system will limit engine speed.

Each warning system of PGM-FI, ACG, oil pressure, and overheat is activated as described in the following table.

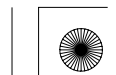



## OPERATION

System Symptom	INDICATOR LIGHTS				BUZZER
	Oil pressure (Green)	Overheat (Red)	ACG (Red)	PGM-FI (Red)	CORRESPONDING SYSTEM
At starting	ON (2 sec)	ON (2 sec)	ON	ON (2 sec)	With the engine key turned on: ON (2 times)
During operation	ON	OFF	OFF	OFF	OFF
Low oil pressure	OFF	OFF	OFF	OFF	ON (continuously)
Overheat	ON	ON	OFF	OFF	ON (continuously)
ACG warning	ON	OFF	ON	OFF	alternating ON and OFF (at long intervals)
PGM-FI warning	ON*	OFF*	OFF	ON	alternating ON and OFF (at long intervals)

### NOTE:

Some indicator and/or buzzer will be activated at the same time due to the occurrence of a malfunction.

\*: Occasionally may blink due to the occurrence of a malfunction.





## OPERATION

System Symptom	INDICATOR				BUZZER
	Oil pressure Indicator (1)	Overheat Indicator (1)	ACG Indicator (1)	PGM-FI Indicator (1)	CORRESPONDING SYSTEM
At starting	ON (2 sec)	ON (2 sec)	ON (2 sec)	ON (2 sec)	With the engine key turned on: ON (2 times)
During operation	ON	OFF	OFF	OFF	OFF
Low oil pressure	OFF	OFF	OFF	OFF	ON (continuously)
Overheat	ON	ON	OFF	OFF	ON (continuously)
ACG warning	ON	OFF	ON	OFF	alternating ON and OFF (at long intervals)
PGM-FI warning	ON*	OFF*	OFF	ON	alternating ON and OFF (at long intervals)

### NOTE:

Some indicator and/or buzzer will be activated at the same time due to the occurrence of a malfunction.

\*: Occasionally may blink due to the occurrence of a malfunction.

(1) The digital tachometer includes this function.





## OPERATION

When the oil pressure warning system is activated:

1. Stop the engine immediately and check the engine oil level (see page 51 ).
2. If the oil is up to the recommended level, restart the engine. If the oil pressure warning system stops after 30 seconds, the system is normal.

### NOTE:

If the throttle was closed suddenly after cruising at full throttle, the engine speed may drop below the specified idle speed. This could cause the oil pressure warning system to activate momentarily.

3. If the oil pressure warning system stays activated after 30 seconds, return to the closest boat landing and contact your closest authorized Honda outboard motor dealer.

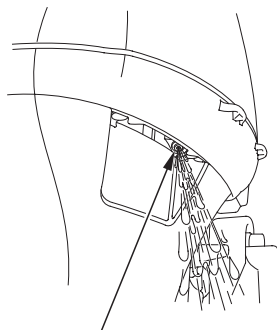

**COOLING WATER CHECK HOLE**

When the overheat warning system is activated:

1. Return the shift lever or remote control lever to the N (neutral) position immediately. Check to see if water is flowing out of the cooling water check hole.
2. If water is flowing out of the cooling water check hole, continue idling for 30 seconds. If the overheat warning system stops after 30 seconds the system is normal.

### NOTE:

If the engine is turned off after running at full throttle, the engine temperature may rise above normal. If the engine is restarted, shortly after being turned off, the overheat warning system could be activated momentarily.





## OPERATION

---

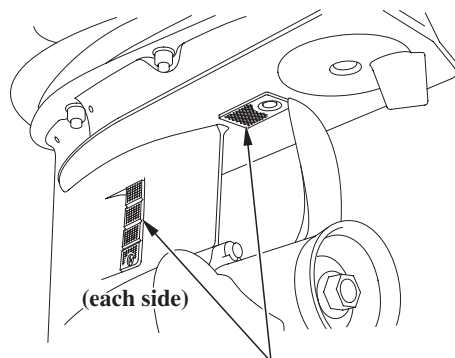

**COOLING WATER INTAKE PORT**

3. If the overheat warning system stays activated, stop the engine. Tilt up the outboard motor and check the water intakes for obstructions. If there are no obstructions at the water intakes, return to the closest boat landing and contact your closest authorized Honda outboard motor dealer.

When the PGM-FI activated:

1. Consult with an authorized Honda outboard motor dealer.

When the ACG warning system is activated:

1. Check the battery (see page 115). If the battery is OK, consult with an authorized Honda outboard motor dealer.

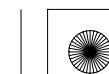



## OPERATION

### < Over-rev Limiter >

This outboard motor is equipped with an engine over-rev limiter which activates when the engine speed increases excessively. The over-rev limiter can be activated while cruising, tilting up the outboard motor, or when ventilation occurs during a sharp turn.

When the over-rev limiter is activated:

1. Reduce the throttle opening immediately and check the trim angle.
2. If the trim angle is correct but the over-rev limiter stays activated, stop the engine, check the condition of the outboard motor, check to see if the correct propeller is installed and check it for damage.

Correct or service as necessary, by contacting your authorized Honda outboard motor dealer.

### < Anode >

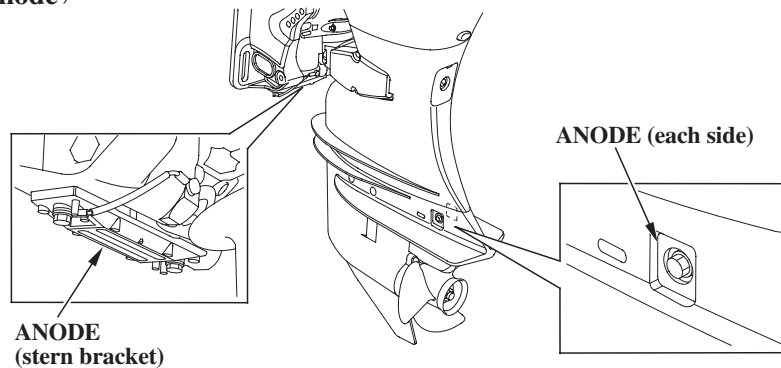

The anode is a sacrificial material which helps to protect the outboard motor from corrosion.

#### NOTICE

**Painting or coating the anode will lead to rust and corrosion damage to the outboard motor.**

There are also 2 small sacrificial anodes in the water passages of the engine block.





## OPERATION

---

### Shallow Water Operation

**NOTICE**

**Excessive trim/tilt angle during operation can cause the propeller to raise out of the water and cause propeller ventilation and engine over-revving. Excessive trim/tilt angle can also damage the water pump and overheat the engine.**

When operating in shallow water, tilt the outboard motor up to prevent the propeller and gear case from hitting the bottom (see page 85 ). With the outboard motor tilted up, operate the outboard motor at low speed.

Monitor the cooling water check hole for water discharge. Be sure that the outboard motor is not tilted so high that the water intakes are out of the water.

If an excessive amount of throttle is used when operating in forward gear, the outboard motor will return to the transom angle adjusting rod. (G type)

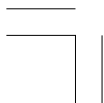





## 9. STOPPING THE ENGINE

### Emergency Engine Stop

(H type)

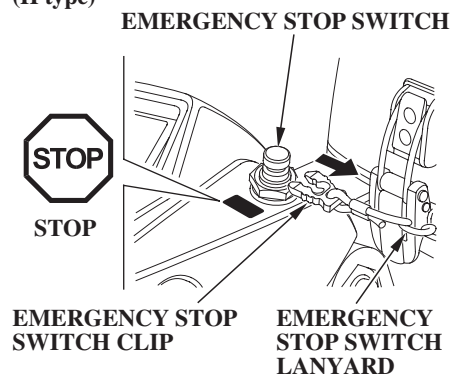

(R1 type)

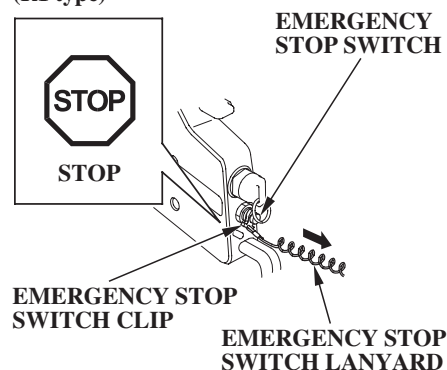

To stop the engine in an emergency, pull the emergency stop switch clip out of the emergency stop switch by pulling the emergency stop switch lanyard.

We suggest that you stop the engine this way occasionally to verify that the emergency stop switch is operating properly.

Before leaving the dock, check the operation of the emergency stop switch.

Turn the engine switch key to the OFF position after verifying the emergency stop switch operation.





## STOPPING THE ENGINE

### Normal Engine Stop (H type)

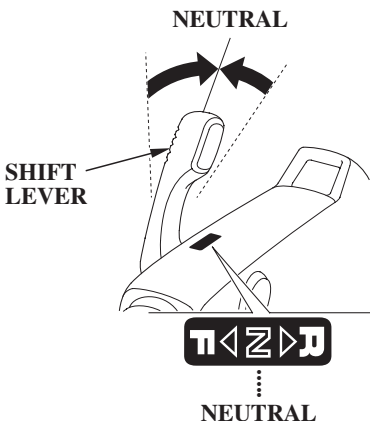
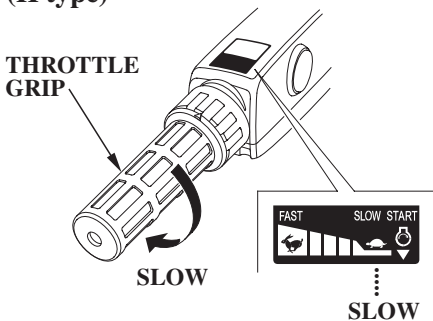

1. Turn the throttle grip to SLOW position and move the shift lever to NEUTRAL.

#### NOTE:

After sailing with the throttle fully open, cool down the engine by running it at the idle speed for a few minutes.

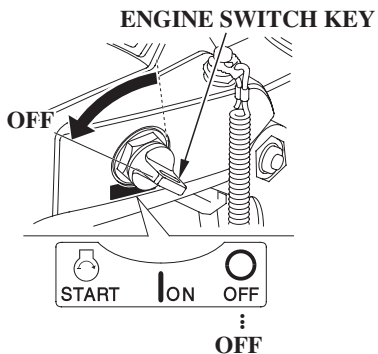

2. Turn the engine switch key to the OFF position to stop the engine.

#### NOTE:

In the event that the engine does not stop when the engine switch key is turned to OFF, pull the emergency stop switch clip out of the emergency stop switch by pulling the emergency stop switch lanyard (see page 61).

3. When the boat is not in use, remove and store the engine switch key and the emergency stop switch lanyard.

If you are using a portable fuel tank, disconnect the fuel line if you will be storing or transporting the outboard motor.

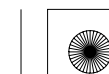



## STOPPING THE ENGINE

(R type)

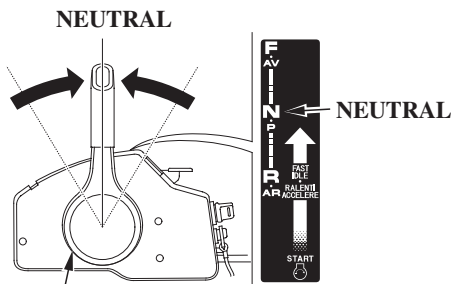

REMOTE CONTROL LEVER

(R1 type)

1. Move the remote control lever to the NEUTRAL position.

**NOTE:**

After sailing with the throttle fully open, cool down the engine by running it at the idle speed for a few minutes.

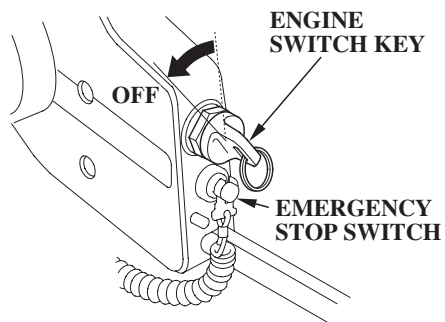

(R1 type)

2. Turn the engine switch key to the OFF position to stop the engine.

**NOTE:**

In the event that the engine does not stop when the engine switch key is turned to OFF, pull the emergency stop switch clip out of the emergency stop switch by pulling the emergency stop switch lanyard (see page 65 ). If you are using a portable fuel tank, disconnect the fuel line if you will be storing or transporting the outboard motor.

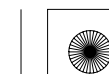



## 10. TRANSPORTING

### Fuel Line Disconnection

Before transporting the outboard motor, disconnect and remove the fuel line in the following procedure.

**▲WARNING**

**Gasoline is extremely flammable, and gasoline vapor can explode, causing serious injury or death.**

- **Be careful not to spill fuel. Spilled fuel or fuel vapor may ignite. If any fuel is spilled, make sure the area is dry before storing or transporting the outboard motor.**
- **Do not smoke or allow flames or sparks where fuel is drained or stored.**

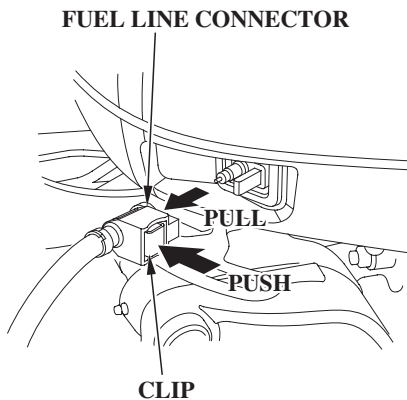

1. While pressing the fuel line connector clip, pull the fuel line connector and disconnect it from the outboard side joint.

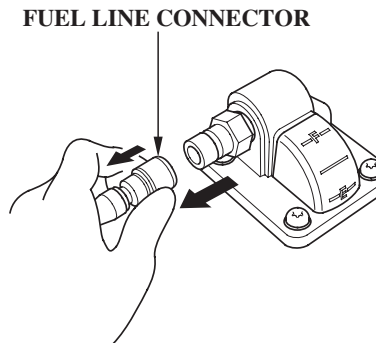

2. While pulling the fuel line connector cover, pull the fuel line connector to disconnect the fuel line connector from the fuel tank.

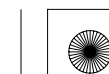



## TRANSPORTING

### Transporting

**▲ CAUTION**

**Do not carry the outboard motor by the engine cover. The engine cover can be unlatched and outboard motor can drop, resulting in an accidental injury and damage.**

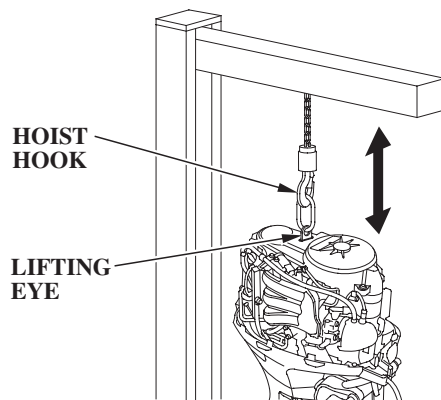

When transporting the outboard motor on a vehicle, perform the following.

1. Remove the engine cover (see page 50 ), and drain the vapor separator (see page 130 ).
2. Set the hoist hook against the lifting eye and hang the outboard motor to remove it from the boat.

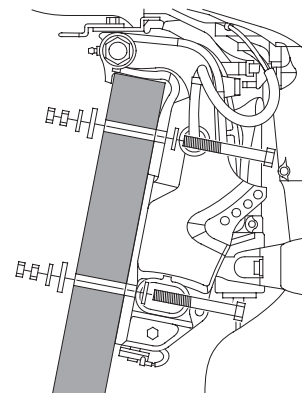

3. Secure the outboard motor on an outboard motor stand with the mounting bolts and nuts.





## TRANSPORTING

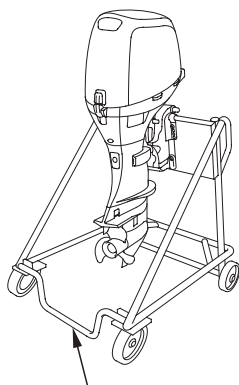

OUTBOARD MOTOR STAND

4. Remove the hoist hook and reinstall the engine cover.

**Horizontal transport or storage:  
Rest the outboard motor on the case protector.**

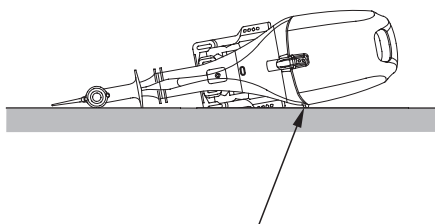

CASE PROTECTOR

**CAUTION**

**Before transporting the outboard motor horizontally, be sure to drain the gasoline and oil from the outboard motor as instructed on pages 111 and 130.**

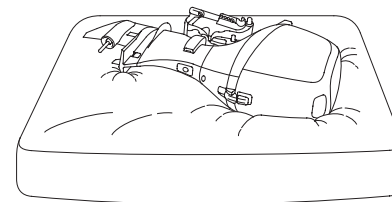

When you place the outboard motor horizontally to transport, be sure to place sponge or clothes under the outboard motor to protect it from impact and damage.

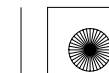



## TRANSPORTING

### Trailer (H type)

STEERING FRICTION  
ADJUSTER

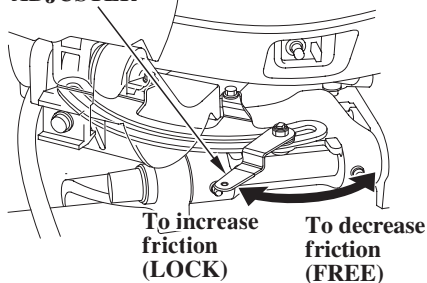

When trailering or transporting the boat with the outboard motor attached always disconnect the fuel line from the portable fuel tank and move the steering friction lever locked position (see page 56 ).

### (R type)

When trailering or transporting the boat with the outboard motor attached, it is recommended that the outboard motor remain in normal running position.

#### NOTICE

**Do not trailer or transport the boat with the outboard motor in the tilted position. The boat or outboard motor could be severely damaged if the outboard motor drops.**

The outboard motor should be trailered in the normal running position. If there is insufficient road clearance in this position, then trailer the outboard motor in the tilted position using an outboard motor support device such as a transom saver bar, or remove the outboard motor from the boat.

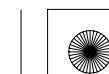



## 11. CLEANING AND FLUSHING

After each use in salt water or dirty water, thoroughly clean and flush the outboard motor with fresh water.

### NOTICE

Do not apply water or corrosion inhibitor directly to the belt and electrical components under the engine cover, such as the timing belt or O2 sensor. If water or corrosion inhibitor penetrates these components, they may be damaged. Before applying a corrosion inhibitor, cover the belt and O2 sensor with a protective material to prevent damage.

### ▲WARNING

- For safety, the propeller must be removed.
- Be sure the outboard motor is securely mounted, and do not leave it unattended while running.
- Keep children and pets away from the area, and stay clear of moving parts during this procedure.

### NOTICE

Running the engine without water can cause serious engine damage due to overheating. Be sure that water flows from the cooling water check hole while the engine is running. If not, stop the engine and determine the cause of the problem.

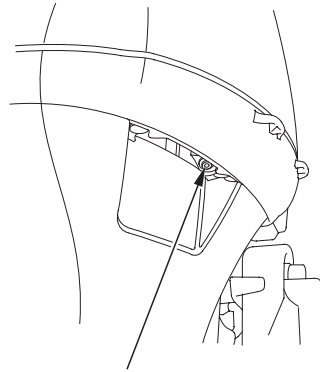

COOLING WATER CHECK HOLE

### With Water Hose Joint (Optional part)

WATER HOSE JOINT (optional)

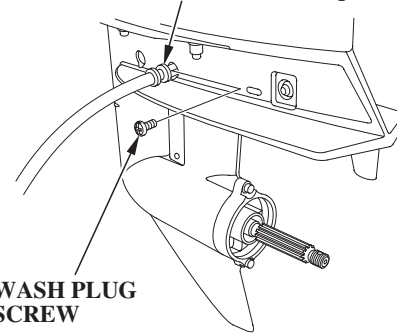

WASH PLUG SCREW

1. Tilt down the outboard motor.
2. Clean and wash the outside of the outboard motor with fresh water.
3. Remove the wash plug screw.
4. Insert the water hose joint into the plug screw hole and connect the hose from a fresh water faucet to the hose joint.







## CLEANING AND FLUSHING

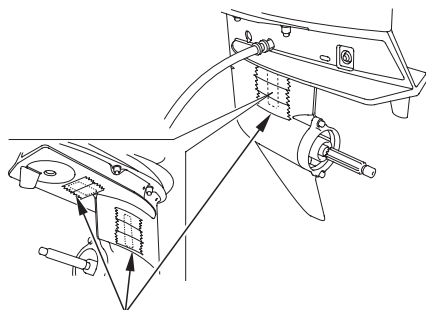

**COOLING WATER INTAKE PORT**

5. Plug the three cooling water intake ports with tape.
6. Remove the propeller (see page 125 ).
7. Move the shift lever or control lever to the NEUTRAL position.
8. Turn on the fresh water supply to the hose.
9. Start the engine and run in neutral position for at least 10 minutes to clean inside of the engine.
10. After flushing, stop the engine, and disconnect the fuel line from the outboard motor. Remove the hose joint, and reinstall the wash plug and the propeller (see page 125 ).
11. Remove the tape from the three cooling water intake ports.
12. Tilt up the outboard motor and move the tilt lock lever to the LOCK position.

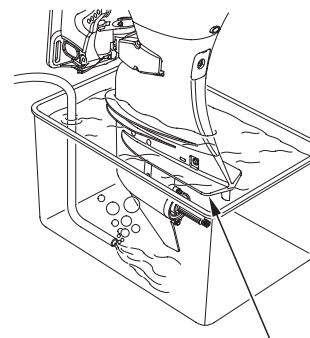

**ANTICAVITATION PLATE**

### Without Water Hose Joint

When the water hose joint is not used, stand the outboard in a suitable container of fresh water.

1. Tilt down the outboard motor.
2. Clean and wash the outside of the outboard motor with fresh water.
3. Remove the propeller (see page 125 ).
4. Stand the outboard motor in a suitable container of water. The water level must be at least 100 mm (4 in) above the anticavitation plate.

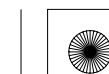



## CLEANING AND FLUSHING

---

5. Move the shift lever or control lever to the NEUTRAL position.
6. Turn on the fresh water supply to the hose.
7. Start the engine and run in neutral for at least 5 minutes to clean inside of the engine.
8. After flushing, stop the engine, and disconnect the fuel line from the outboard motor. Reinstall the propeller (see page 125 ).
9. Take out the outboard motor from the container.
10. Tilt up the outboard motor and move the tilt lock lever to the LOCK position.

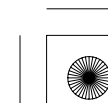
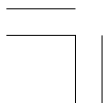



## 12. MAINTENANCE

Periodic maintenance and adjustment are important to keep the outboard motor in the best operating condition. Service and inspect according to the MAINTENANCE SCHEDULE.

### **▲WARNING**

**Shut off the engine before performing any maintenance. If the engine must be run, make sure the area is well ventilated. Never run the engine in an enclosed or confined area. Exhaust contains poisonous carbon monoxide gas; exposure can cause loss of consciousness and may lead to death. Be sure to reinstall the engine cover, if it was removed, before starting the engine. Lock the engine cover fixing lever securely (see page 50).**

### **NOTICE**

- **If the engine must be run, make sure there is water at least 100 mm (4 in) above the anticavitation plate, otherwise the water pump may not receive sufficient cooling water, and the engine will overheat.**
- **Use only Honda Genuine parts or their equivalents for maintenance or repair. The use of replacement parts which are not of equivalent quality may damage the outboard motor.**

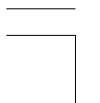



# MAINTENANCE

## Tool Kit and Spare Parts

The following tools and spare parts are supplied with the outboard motor for maintenance, adjustment, and emergency repairs.



OWNER'S MANUAL



10 × 12 mm  
WRENCH



OIL CHECK  
SCREWDRIVER



PHILLIPS/FLAT  
SCREWDRIVER



SCREWDRIVER  
HANDLE



FUSE PULLER

EMERGENCY  
STARTER ROPE

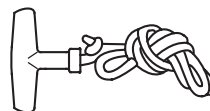

PLIERS

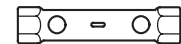

18 × 19 mm  
SOCKET WRENCH



8 mm WRENCH



TOOL BAG

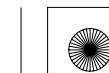



# MAINTENANCE

## MAINTENANCE SCHEDULE

ITEM	REGULAR SERVICE PERIOD (3) Perform at every indicated month or operating hour interval, whichever comes first.	Each use	After use	First	Every	Every	Every	Every	Refer to page
				month or 20 hrs.	6 months or 100 hrs.	year or 200 hrs.	2 years or 400 hrs.	3 years or 600 hrs.	
Engine oil	Check level	○							51
	Change			○	○				111
Gear case oil	Change			○ (2)	○ (2)				—
Engine oil filter	Replace					○ (2)			—
Timing belt	Check-adjust					○ (2)			—
Throttle linkage	Check-adjust			○ (2)	○ (2)				—
Idling speed	Check-adjust			○ (2)	○ (2)				—
Valve clearance	Check-adjust					○ (2)			—
Spark plug	Check-adjust/Replace				○				113
Propeller and cotter pin	Check	○							54
Anode metal (Outside engine)	Check	○							58
Anode metal (Inside engine)	Check						○ (2)		—
Lubrication	Grease			○ (1)	○ (1)				118
Fuel tank and tank filter	Clean					○			122
Thermostat	Check					○ (2)			—

**NOTE:**

- (1) Lubricate more frequently when used in salt water.
- (2) These items should be serviced by your servicing dealer, unless you have the proper tools and are mechanically proficient. Refer to the Honda Shop Manual for service procedures.
- (3) For professional commercial use, log hours of operation to determine proper maintenance intervals.





## MAINTENANCE

ITEM	REGULAR SERVICE PERIOD (3) Perform at every indicated month or operating hour interval, whichever comes first.	Each use	After use	First	Every	Every	Every	Every	Refer to page
				month or 20 hrs.	6 months or 100 hrs.	year or 200 hrs.	2 years or 400 hrs.	3 years or 600 hrs.	
Fuel filter (Low pressure type)	Check Replace	○ (5)			○			○	119
Fuel filter (High pressure type)	Check Replace				○ (2)			○ (2)	—
Fuel line	Check Replace	○ (8)							58
				Every 2 years (if necessary) (2) (9)					—
Battery and cable connection	Check level-tightness	○							57, 115
Bolts and Nuts	Check-tightness			○ (2)	○ (2)				—
Crankcase breather tube	Check					○ (2)			—
Cooling water passages	Clean		○ (4)						—
Water pump	Check					○ (2)			—
Emergency stop switch	Check	○							—
Engine oil leak	Check	○							—
Each operation part	Check	○							—
Engine condition (6)	Check	○							—
Power Trim/Tilt	Check				○ (2)				—
Shift cable	Check-adjust				○ (2)(7)				—

### NOTE:

- (2) These items should be serviced by your servicing dealer, unless you have the proper tools and are mechanically proficient. Refer to the Honda Shop Manual for service procedures.
- (3) For professional commercial use, log hours of operation to determine proper maintenance intervals.
- (4) When operating in salt water, turbid or muddy water, the engine should be flushed with clean water after each use.
- (5) Check for water and contamination.
- (6) Upon starting, check for unusual engine sounds and cooling water flowing freely from the check hole.
- (7) The user who performs shift operation frequently will recommend you exchange of a shift cable around three years.
- (8) Check the fuel line for leaks, cracks, or damage. If it is leaking, cracked, or damaged, take it to your servicing dealer for replacement before using your outboard.
- (9) Replace the fuel line if there are signs of leaks, cracks, or damage.





## MAINTENANCE

### Engine Oil

Insufficient or contaminated engine oil adversely affects the service life of the sliding and moving parts.

### Oil change interval:

20 operating hours after the date of purchase or first month for initial replacement, then every 100 operating hours or 6 months.

### Oil capacity:

2.0 L (2.1 US qt, 1.8 Imp qt)  
...when oil filter is not replaced.

2.1 L (2.2 US qt, 1.8 Imp qt)  
...when oil filter is replacement.

### Recommended Oil:

SAE 5W-30 engine oil or equivalent, API Service classification SG, SH or SJ.

### < Engine Oil Replacement >

#### OIL FILLER CAP

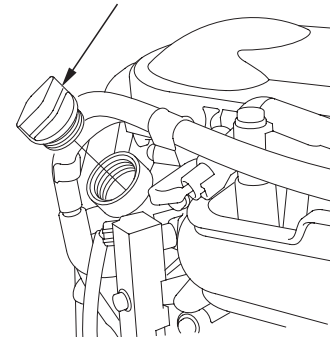

Drain the oil while the engine is still warm to assure rapid and complete draining.

1. Position the outboard motor vertically, and remove the engine cover. Remove the oil filler cap.





## MAINTENANCE

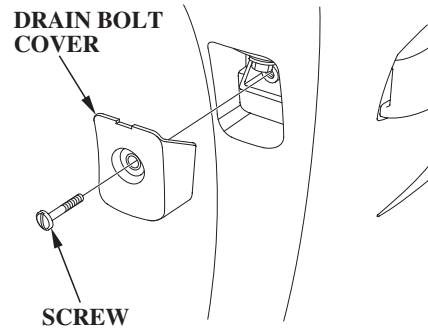

2. Loosen the drain bolt cover screw using a flat screwdriver and remove the drain bolt cover.

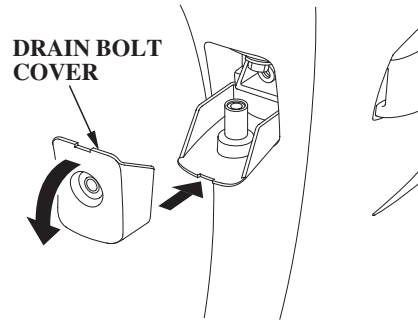

3. Place the drain bolt cover as shown to use it as a drain oil guide. Place a suitable container under the guide.

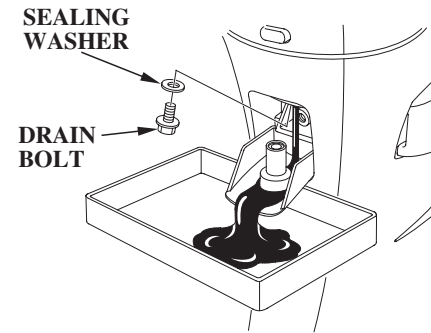

4. Remove the engine oil drain bolt and sealing washer using the 12 mm wrench and drain the engine oil.

Install a new sealing washer and drain bolt, and tighten bolt securely.

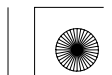





## MAINTENANCE

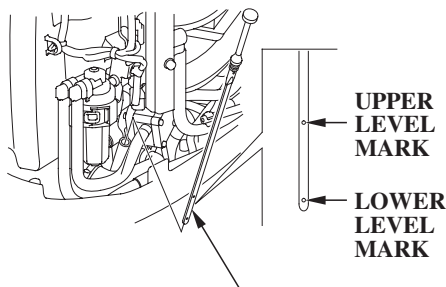

OIL LEVEL DIPSTICK

5. Refill to the upper level mark on the oil level dipstick with the recommended oil.
6. Install the dipstick and drain bolt cover securely.

7. Reinstall the oil filler cap securely. Do not overtighten.
8. Install and lock the engine cover securely.

### NOTE:

Please dispose of used motor oil in a manner that is compatible with the environment. We suggest you take it in a sealed container to your local service station for reclamation. Do not throw it in the trash, pour it on the ground or down a drain.

Wash your hands with soap and water after handling used oil.

### Spark Plugs

To ensure proper engine operation, the spark plug must be properly gapped and free of deposits.

### ▲ CAUTION

**The spark plug becomes very hot during operation and will remain hot for a while after stopping the engine. Allow the engine to cool before servicing the spark plug.**

### Check-Adjust interval:

Every 100 operating hours or 6 months.

### Replacement interval:

Every 100 operating hours or 6 months.

### Recommended spark plug:

DR7EB (NGK)

X22ESR-UB (DENSO)

### NOTICE

**Use only the recommended spark plugs or equivalent. Spark plugs which have an improper heat range may cause engine damage.**





## MAINTENANCE

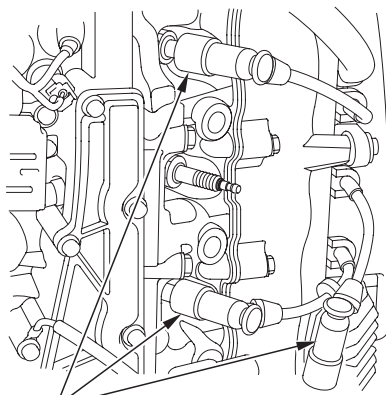

**SPARK PLUG CAP**

**SPARK PLUG WRENCH**



1. Remove the engine cover.
2. Remove the spark plug caps.
3. Use the spark plug wrench and screwdriver supplied in the tool kit to remove the spark plugs.

**New plug**

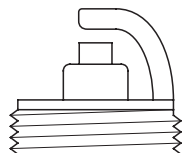

**Plug needing replacement**

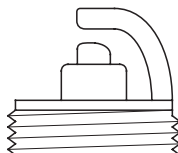

4. Inspect the spark plugs.
  - (1) If the electrodes are heavily corroded or carbon-soiled, clean with a wire brush.

- (2) Replace a spark plug if the central electrode is worn. The spark plug can wear out in different ways. If the sealing washer shows signs of wear, or if the insulators are cracked or chipped, replace the spark plugs.

**SIDE ELECTRODE**

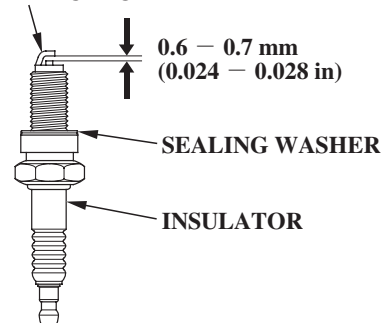

5. Measure the plug gaps with a wire-type feeler gauge. The gaps should be 0.6–0.7 mm (0.024–0.028 in). Correct as necessary by carefully bending the side electrode.

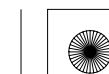



## MAINTENANCE

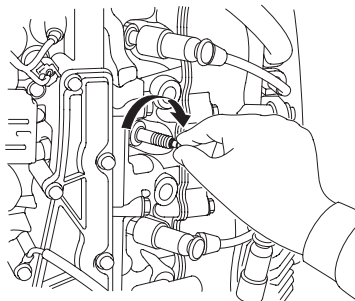

6. Thread the plugs in by hand to prevent cross threading.
7. After the spark plugs are seated, tighten with a spark plug wrench to compress the washers.

### NOTE:

If installing new spark plugs, tighten 1/2 turn after the spark plugs seat to compress the washers.

If reinstalling used spark plugs, tighten 1/8 – 1/4 turn after the spark plugs seat to compress the washers.

### NOTICE

**The spark plugs must be securely tightened. An improperly tightened plug can become very hot and may cause engine damage.**

8. Attach the spark plug caps.
9. Install and lock the engine cover securely.

### Battery

#### NOTICE

Battery handling differs according to the type of the battery and the instructions described below might not be applicable to the battery of your outboard. Refer to the battery manufacturer's instructions.

#### ▲WARNING

**Batteries produce explosive gases: If ignited, an explosion can cause serious injury or blindness. Provide adequate ventilation when charging.**

- **CHEMICAL HAZARD: Battery electrolyte contains sulfuric acid. Contact with eyes or skin, even through clothing, may cause severe burns. Wear a faceshield and protective clothing.**





## MAINTENANCE

- **Keep flames and sparks away, and do not smoke in the area.**  
**ANTIDOTE:** If electrolyte gets into your eyes, flush thoroughly with warm water for at least 15 minutes and call a physician immediately.
- **POISON: Electrolyte is poison.**  
**ANTIDOTE:**
  - **External:** Flush thoroughly with water.
  - **Internal:** Drink large quantities of water or milk. Follow with milk of magnesia or vegetable oil, and call a physician immediately.
- **KEEP OUT OF REACH OF CHILDREN.**

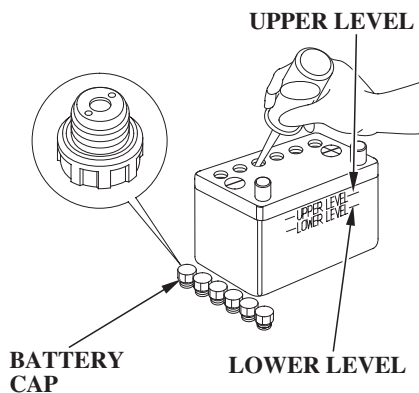

### 〈 Battery Fluid Level 〉

Check whether the battery fluid is between the upper and lower levels, and check the vent hole in the battery caps for clogging. If the battery fluid is near or below the lower level, add the distilled water to the upper level.

### 〈 Battery Cleaning 〉

1. Disconnect the battery cable at the battery negative (−) terminal, then at the battery positive (+) terminal.
2. Remove the battery and clean the battery terminals and battery cable terminals with a wire brush or sand paper.  
Clean the battery with a solution of baking soda and warm water, taking care not to get the solution or water in the battery cells. Dry the battery thoroughly.

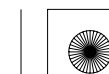



## MAINTENANCE

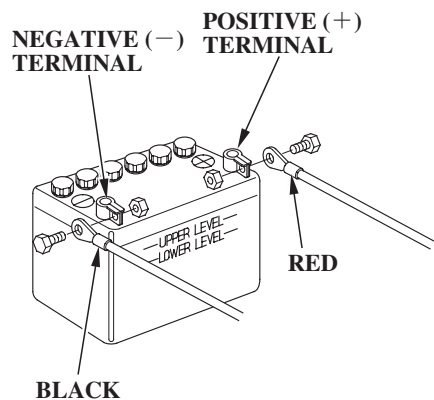

### **⚠ CAUTION**

When disconnecting the battery cable, be sure to disconnect at the battery negative (-) terminal first. To connect, connect at the positive (+) terminal first, then at the negative (-) terminal. Never dis/connect the battery cable in the reverse order, or it causes a short circuit when a tool contacts the terminals.

3. Connect the battery positive (+) cable to the battery positive (+) terminal, then the battery negative (-) cable to the battery negative (-) terminal. Tighten the bolts and nuts securely. Coat the battery terminals with grease.

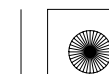



# MAINTENANCE

## Lubrication

Wipe the outside of the engine with a cloth dipped in clean oil. Apply marine anticorrosion grease to the following parts:

## Lubrication interval:

20 hours or a month after the date of purchase for initial lubrication, then every 100 hours or 6 months.

## NOTE:

- Apply anticorrosion oil to pivot surfaces where grease cannot penetrate.
- Lubricate more frequently when used in salt water.

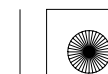
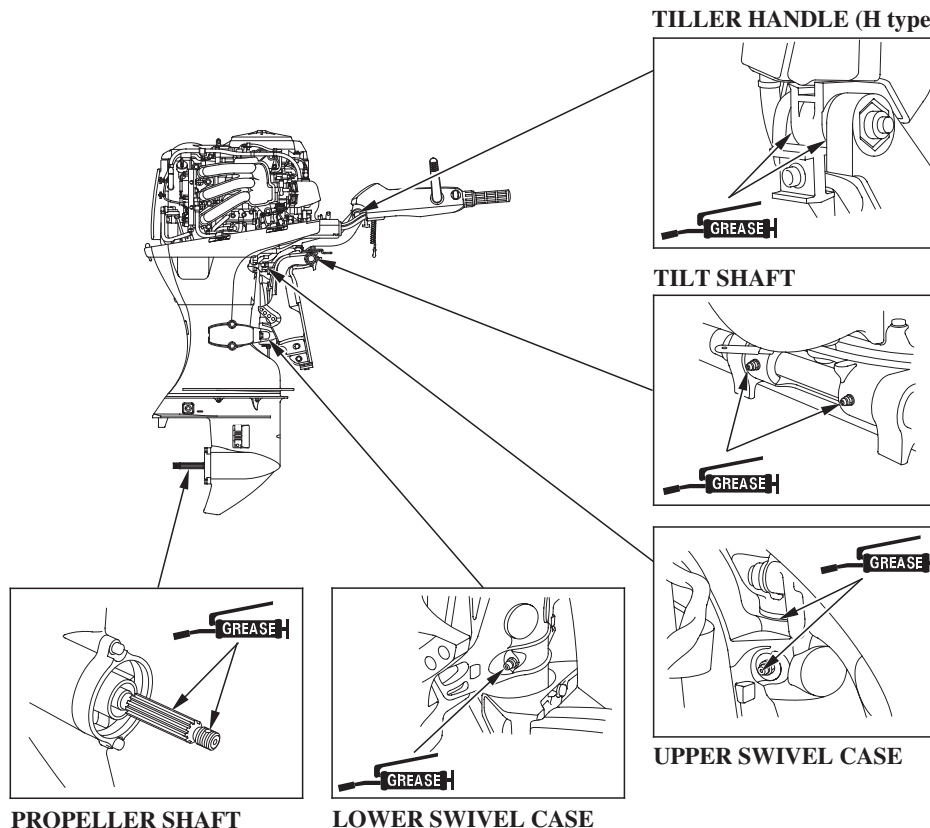



## MAINTENANCE

### Fuel Filter

The fuel filter is located between the fuel coupling and the fuel pump. Water or sediment accumulated in the fuel filter can cause loss of power or hard starting. Check and replace the fuel strainer periodically.

### Inspection interval:

Every 100 operating hours or 6 months.

### Replacement interval:

Every 400 operating hours or 2 years

### ▲WARNING

**Gasoline is extremely flammable, and gasoline vapor can explode, causing serious injury or death. Do not smoke or allow flames or sparks in your working area. KEEP OUT OF REACH OF CHILDREN.**

- Always work in a well-ventilated area.
- Be sure that any fuel drained from the outboard motor is stored in a safe container.
- Be careful not to spill fuel when replacing the filter. Spilled fuel or fuel vapor may ignite. If any fuel is spilled, make sure the area is dry before starting the engine.

### < Inspection >

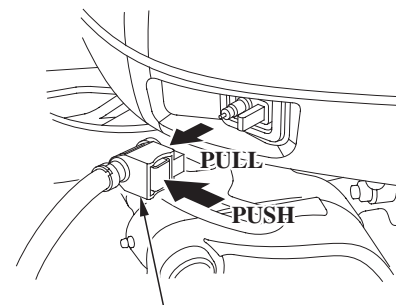

FUEL LINE CONNECTOR

1. Disconnect the fuel line connector from the outboard motor.
2. Remove the engine cover (see page 50 ).

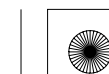



## MAINTENANCE

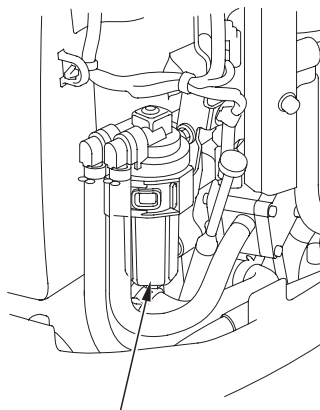

**FUEL FILTER**  
(inside strainer cup)

- Looking through the translucent strainer cup, check the fuel filter for water accumulation and clogging.  
If necessary, clean the fuel filter or replace the fuel strainer with a new one.

### < Replacement >

#### FUEL FILTER BRACKET

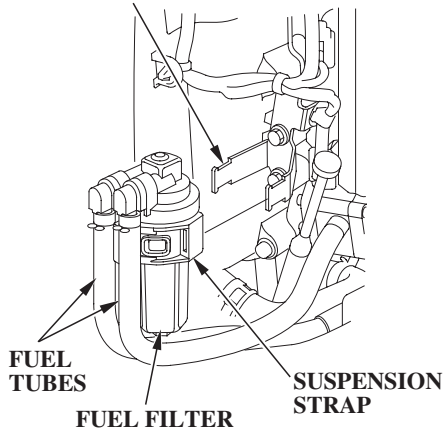

**FUEL TUBES**

**FUEL FILTER**

**SUSPENSION STRAP**

- Remove the suspension strap from the fuel filter bracket, then remove the strap from the fuel filter assembly.

#### NOTE:

Before removing the filter, pinch the fuel tubes on each side of filter using tube clips to prevent fuel leakage.

#### SUSPENSION STRAP

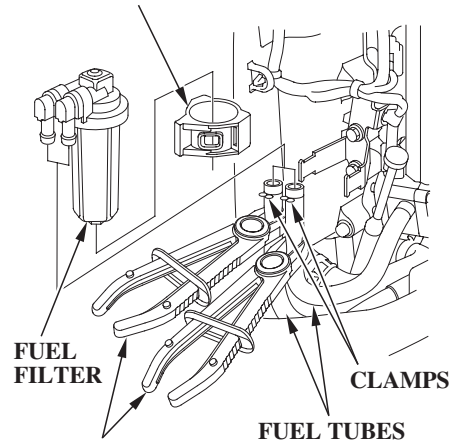

**FUEL FILTER**

**CLAMPS**

**FUEL TUBES**

**TUBE CLIPS**  
(commercially available)

- Disconnect the fuel tubes from the fuel filter.

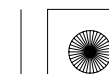





## MAINTENANCE

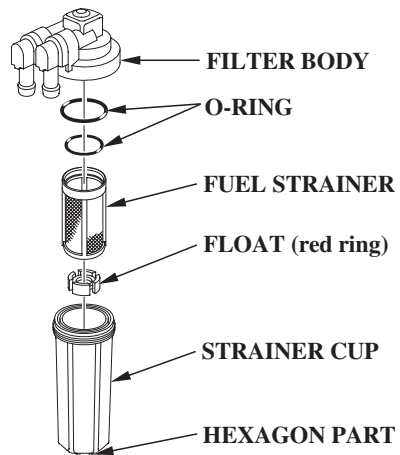

- Turn the hexagon part to counterclockwise and separate the strainer cup from the filter body.
- Thoroughly clean the strainer cup and fuel strainer. If the fuel strainer is clogged, replace it with a new one.

- Install the fuel strainer, O-rings and float. Re-assemble the filter body and the strainer cup.

**TIGHTENING TORQUE:**  
 3.0 N·m (0.3 kgf·m , 2.2 lbf·ft)

Align the center of the two fuel tubes and the arrow of the suspension strap rib

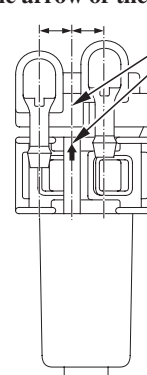

- Install the suspension strap to the fuel filter assembly as shown above.
- Reinstall the fuel filter assembly and suspension strap in the original position.

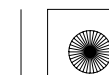



## MAINTENANCE

8. Connect the fuel line connector to the fuel tank and outboard motor securely.  
Turn the vent knob to OPEN side, squeeze and release the priming bulb to feed the fuel, (see page 60 ) and check for fuel leaks.  
Repair any fuel leaks if necessary.

### NOTE:

If loss of power or hard starting are found to be caused by excessive water or sediment accumulation in the fuel filter, inspect the fuel tank.

Clean the fuel tank and tank filter if necessary. It may be necessary to drain the fuel tank completely and refill with fresh gasoline.

### Fuel Tank and Tank Filter (equipped type)

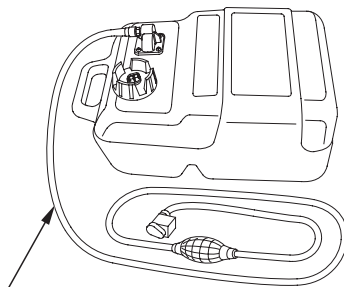

FUEL LINE

### Cleaning interval:

Every year or after every 200 hours of outboard motor operation.

### < Fuel Tank Cleaning >

#### ▲WARNING

**Gasoline is extremely flammable, and gasoline vapor can explode, causing serious injury or death. Do not smoke or allow flames or sparks in your working area. KEEP OUT OF REACH OF CHILDREN.**

- Always work in a well-ventilated area.
- Be sure that any fuel drained from the fuel tank is stored in a safe container.
- Be careful not to spill fuel when cleaning the tank and filter. Spilled fuel or fuel vapor may ignite. If any fuel is spilled, make sure the area is dry before starting the engine.

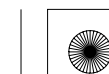



## MAINTENANCE

1. Disconnect the fuel line from fuel tank.
2. Empty the tank, pour in a small quantity of gasoline, and clean the tank thoroughly by shaking it. Drain and dispose of the gasoline properly.

### 〈 Tank Filter Cleaning 〉

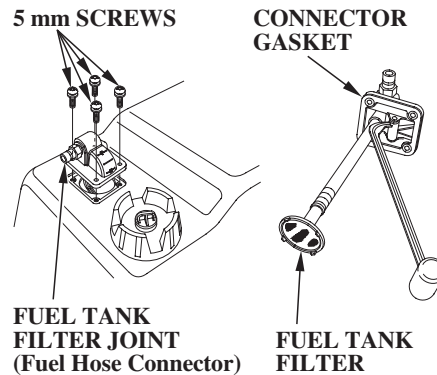

1. Remove the four 5 mm screws using a flat screwdriver, then remove the fuel hose connector and fuel tank filter from the tank.
2. Clean the filter in nonflammable solvent. Inspect the fuel tank filter and the connector gasket. Replace them if damaged.
3. Reinstall the filter and hose connector in the fuel tank. Tighten the four 5 mm screws securely.

### EMISSION CONTROL SYSTEM

The combustion process produces carbon monoxide and hydrocarbons. Control of hydrocarbons is very important because under certain conditions, they react to form photochemical smog when subjected to sunlight. Carbon monoxide does not react in the same way, but it is toxic.

#### Problems that May Affect Outboard Motor Emissions

If you are aware of any of the following symptoms, have the outboard motor inspected and repaired by your authorized Honda Dealer:

1. Hard starting or stalling after starting
2. Rough idle
3. Misfiring or backfiring during acceleration
4. Poor performance (driveability) and poor fuel economy





## MAINTENANCE

### Fuse

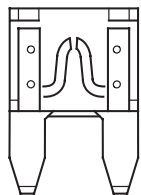

**BLOWN FUSE**

If the fuse blows, running the engine will not charge the battery. Before replacing the fuse, check the current ratings of the electrical accessories and ensure that there are no abnormalities.

**▲WARNING**

- **Never use a fuse with a different rating from that specified. Serious damage to the electrical system or a fire may result.**
- **Disconnect the battery cable at the battery negative (–) terminal before replacing the fuse. Failure to do so may cause a short circuit.**

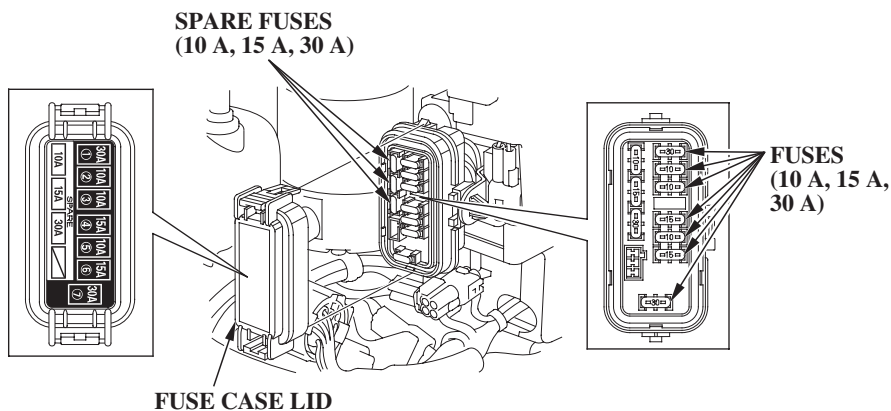

**FUSE PULLER**  
(supplied in the tool bag)

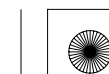
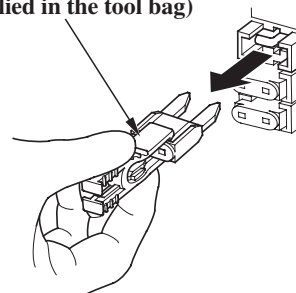



## MAINTENANCE

### NOTICE

If the fuse is blown, check the cause, then replace the fuse with a spare fuse of the same rated capacity. Unless the cause is found, the fuse may blow again.

#### < Replacement >

1. Stop the engine, then disconnect the battery cable.
2. Remove the engine cover.
3. Remove the fuse case lid and pull the old fuse out of the clip with the fuse puller supplied in the tool bag.
4. Push a new fuse into the clips.

**DESIGNATED FUSE:**  
10 A, 15 A, 30 A

### Propeller

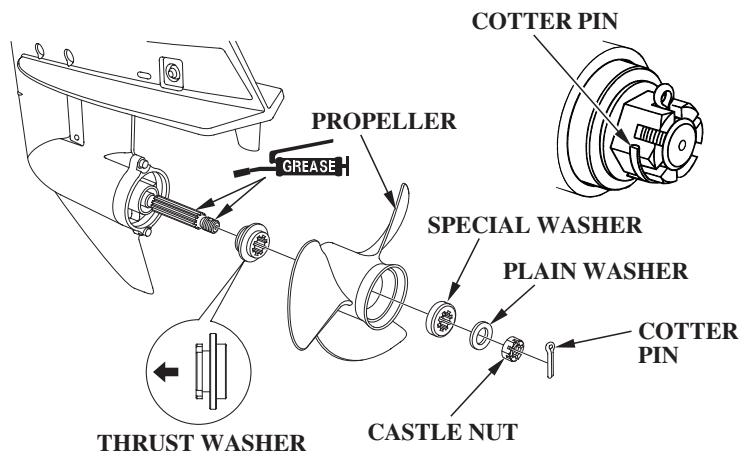

If the propeller is damaged by striking a rock, or other obstacle, replace the propeller as follows.

### ▲WARNING

- Before replacing the propeller, remove the emergency stop switch clip from the emergency stop switch to prevent any possibility of the engine being started while you are working with the propeller.

- The propeller blades may have sharp edges, so wear heavy gloves to protect your hands.

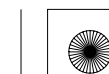



## MAINTENANCE

### < Removal >

1. Remove the cotter pin, unscrew the castle nut, remove the washers, then remove the propeller and thrust washer.
2. Inspect the propeller shaft for any fishing line or debris.

### < Installation >

1. Apply marine grade grease to the propeller shaft.
2. Install the thrust washer with the grooved side toward the gear case.
3. Install the propeller.
4. Install the special washer and plain washer with as shown.
5. Lightly tighten the castle nut by hand or wrench until the propeller has no free play.

6. Tighten the castle nut using torque wrench.

**CASTLE NUT  
TIGHTENING TORQUE:  
1 N·m (0.1 kgf·m, 0.74 lbf·ft)**

7. Then using a torque wrench, tighten the castle nut until the first available groove in the castle nut aligns with the cotter pin hole. Do not tighten past the first alignment of the castle nut groove and the cotter pin hole.

**NOTICE**

**TIGHTENING TORQUE LIMIT:  
34 N·m (3.5 kgf·m , 25 lbf·ft)  
Do not tighten the castle nut above  
the TIGHTENING TORQUE  
LIMIT or the propeller and shaft  
may be damaged.**

8. Be sure to replace the cotter pin with a new one.

- Use a Honda Genuine stainless steel cotter pin or equivalent cotter pin and bend the pin ends as shown the previous page.

Note that these wrenches are not included with the tool set that comes with the outboard motor. Contact your authorized Honda marine dealer for additional tool information.

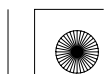



## MAINTENANCE

### Submerged Outboard Motor

A submerged outboard motor must be serviced immediately after it is recovered from the water in order to minimize corrosion.

If there is a Honda outboard motor dealer nearby, take the outboard motor immediately to the dealer. If you are far from a dealer, proceed as follows:

1. Remove the engine cover, and rinse the outboard motor with fresh water to remove salt water, sand, mud, etc.

**NOTICE**

**If the outboard motor was running when it submerged, there may be mechanical damage, such as bent connecting rods. If the engine binds when cranked, do not attempt to run the outboard motor until it has been repaired.**

2. Drain the vapor separator as described on page 130 .

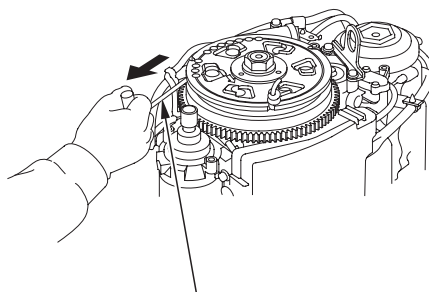

**EMERGENCY STARTER ROPE**

3. Change the engine oil (see page 111).
4. Remove the spark plugs. Remove the ACG cover and wind the emergency starter rope following the emergency starting procedure (pages 68 through 73 ) and drain the water from the cylinder by pulling the emergency starter rope several times.

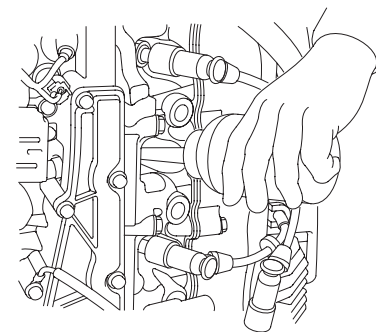

5. Pour a teaspoon of engine oil into each spark plug hole, then pull the emergency starter rope several times to lubricate the inside of the cylinders. Reinstall the spark plugs.
6. Install the engine cover and lock the fixing lever securely (see page 50 ).

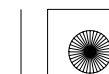



## MAINTENANCE

---

7. Attempt to start the engine.
  - If the engine fails to start, remove the spark plugs, clean and dry the electrodes, then reinstall the spark plugs and attempt to start the engine again.
  - If there was water in the engine crankcase, or the used engine oil showed signs of water contamination, then a second engine oil change should be performed after running the engine for 1/2 hour.
  - If the engine starts, and no mechanical damage is evident, continue to run the engine for 1/2 hour or longer (be sure the water level is at least 100 mm (4 in) above the anticavitation plate).
8. As soon as possible, take the outboard motor to a Honda outboard motor dealer for inspection and service.

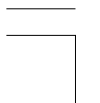





## 13. STORAGE

For longer service life of the outboard motor, have your outboard motor serviced by an authorized Honda outboard motor dealer before storage. However, the following procedures can be performed by you, the owner, with a minimum of tools.

### Fuel

#### NOTE:

Gasoline spoils very quickly depending on factors such as light exposure, temperature and time. In worst cases, gasoline can be contaminated within 30 days. Using contaminated gasoline can seriously damage the engine (fuel system clogged, valve stuck). Such damage due to spoiled fuel is disallowed from coverage by the warranty. To avoid this please strictly follow these recommendations:

- Only use specified gasoline (see page 52 ).
- Use fresh and clean gasoline.

- To slow deterioration, keep gasoline in a certified fuel container.
- If long storage (more than 30 days) is foreseen, drain fuel tank and vapor separator.

#### ▲WARNING

**Gasoline is extremely flammable, and gasoline vapor can explode, causing serious injury or death. Do not smoke or allow flames or sparks in your working area. KEEP OUT OF REACH OF CHILDREN.**

- **Be careful not to spill fuel. Spilled fuel or fuel vapor may ignite. If any fuel is spilled, make sure the area is dry before storing or transporting the outboard motor.**
- **Do not smoke or allow flames or sparks where fuel is drained or stored.**

1. Check the fuel filter on the low pressure side. If there is water or any contamination inside, clean the fuel strainer or change the fuel filter. (see page 119 )
2. Drain the gasoline from the vapor separator. (see page 130 )
3. Check that there is no water or any contamination mixed with the extracted gasoline.
4. If there is nothing mixed with the extracted gasoline, tighten the drain screw.





## STORAGE

5. If there is water or contamination mixed with the extracted gasoline, proceed with the following steps.
  - 5-a. Tighten the drain screw.
  - 5-b. Set the outboard vertically and connect to a fuel tank of clean gasoline.
  - 5-c. Sending the fresh gasoline to the vapor separator through the priming valve, start the engine.

### NOTICE

**The propeller must be lowered into the water, running the outboard motor out of the water will damage the water pump and overheat the engine.**

### CAUTION

**Operate the priming valve after confirming the drain screw is tightened. When the drain screw is loose, gasoline will flow out.**

- 5-d. After starting the engine, hold in the idling position for 3 minutes.
- 5-e. Drain the gasoline from the vapor separator.
- 5-f. Check that there is no water or any contamination mixed with the extracted gasoline.
- 5-g. If there is water or contamination mixed with the extracted gasoline, repeat from step 5-a until there is nothing mixed with the extracted gasoline.

### Vapor Separator Draining

### WARNING

**Gasoline is extremely flammable, and gasoline vapor can explode, causing serious injury or death. Do not smoke or allow flames or sparks in your working area. KEEP OUT OF REACH OF CHILDREN.**

- **Be careful not to spill fuel. Spilled fuel or fuel vapor may ignite. If any fuel is spilled, make sure the area is dry before storing or transporting the outboard motor.**
- **Do not smoke or allow flames or sparks where fuel is drained or stored.**

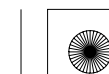



## STORAGE

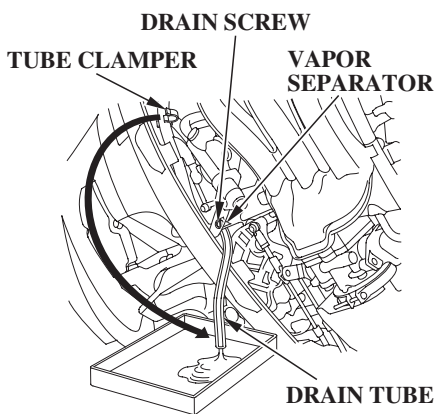

1. Disconnect the fuel line connector (see page 100 ).
2. Remove the engine cover.
3. Release the drain tube from the tube clamber of the high pressure fuel pipe and bring the end of the drain tube out of the engine under case.
4. Loosen the vapor separator drain screw.
5. Tilt up the outboard motor.

6. When the gasoline starts to flow out of the drain tube, tilt down the outboard motor and hold it in the position until the gasoline stops flowing.  
Catch the draining gasoline in a suitable container.
7. After draining, tighten the drain screw and secure the drain tube to the tube clamber of the high pressure fuel pipe.

### NOTE:

Before storing the outboard motor for a prolonged period, we recommend that you remove the fuel line connector and operate the engine at 2,000 to 3,000<sup>-1</sup> (rpm) until it stops.

### Engine Oil

1. Change the engine oil (see pages 111 – 113 ).
2. Remove the spark plugs (see page 113 ), and remove the clip from the emergency stop switch.
3. Pour a tablespoon or teaspoon (5 – 10 cm<sup>3</sup>) of clean engine oil into each cylinder.
4. Rotate the engine a few revolutions to distribute the oil in the cylinders.
5. Reinstall the spark plugs (see page 115 ).





## STORAGE

### Battery Storage

#### NOTICE

Battery handling differs according to the type of the battery and the instructions described below might not be applicable to the battery of your outboard motor. Refer to the battery manufacturer's instructions.

#### ▲WARNING

Batteries produce explosive gases: If ignited, an explosion can cause serious injury or blindness. Provide adequate ventilation when charging.

- **CHEMICAL HAZARD:** Battery electrolyte contains sulfuric acid. Contact with eyes or skin, even through clothing, may cause severe burns. Wear a faceshield and protective clothing.

- **Keep flames and sparks away, and do not smoke in the area. ANTIDOTE:** If electrolyte gets into your eyes, flush thoroughly with warm water for at least 15 minutes and call a physician immediately.
- **POISON:** Electrolyte is poison.  
**ANTIDOTE**
  - External: Flush thoroughly with water.
  - Internal: Drink large quantities of water or milk. Follow with milk of magnesia or vegetable oil, and call a physician immediately.
- **KEEP OUT OF REACH OF CHILDREN.**

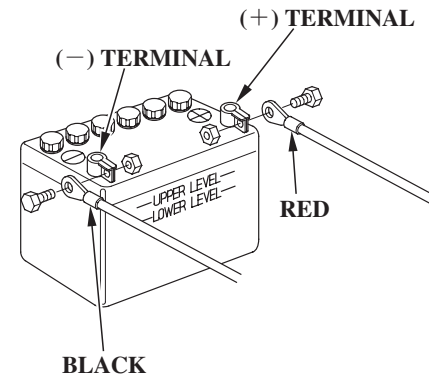

1. Disconnect the battery cable at the battery negative (-) terminal, then at the battery positive (+) terminal.
2. Remove the battery and clean the battery terminals and battery cable terminals with a wire brush or sand paper.  
Clean the battery with a solution of baking soda and warm water, taking care not to get the solution of water in the battery cells. Dry the battery thoroughly.





## STORAGE

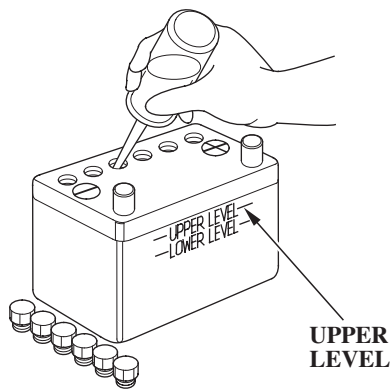

UPPER LEVEL

3. Fill the battery with distilled water to the upper level line. Never overfill the battery.
4. Store the battery on a level surface in a cool, dry, well ventilated place out of direct sunlight.
5. Once a month, check the specific gravity of the electrolyte and recharge as required to prolong battery life.

### Outboard Motor Position

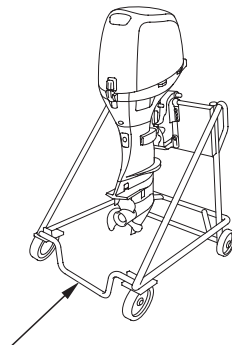

OUTBOARD MOTOR STAND

Transport and store the outboard motor either vertically or horizontally, as shown here. Attach the stern bracket to stand and secure the outboard motor with bolts and nuts. Store the outboard motor in a well-ventilated area free from direct sunlight and humidity.

**Vertical transport or storage:**  
Attach the stern bracket to a stand.

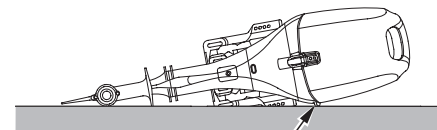

CASE PROTECTOR

(starboard side turned down as shown.)

**Horizontal transport or storage:**  
Rest the outboard motor on the case protector.

**CAUTION**

**Any other transport or storage position may cause damage or oil leakage.**

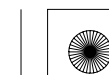



## 14. DISPOSAL

---

To protect the environment, do not dispose of this product, battery, engine oil, etc. carelessly by leaving them in the waste. Observe the local laws and regulations or consult your authorized Honda dealer for disposal.

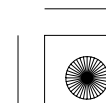
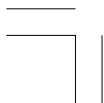



## 15. TROUBLESHOOTING

### WARNING SYSTEM COMES ON

SYMPTOM	POSSIBLE CAUSE	REMEDY
Overheat warning system comes on: <ul style="list-style-type: none"> <li>• Overheat indicator comes on.</li> <li>• Overheat warning buzzer sounds.</li> <li>• Engine speed decreases and stops at last.</li> <li>• Engine speed cannot be increased by opening the throttle.</li> <li>• Engine will stop in 20 seconds after engine speed is limited.</li> </ul>	Cooling water intake port clogged.	Clean the cooling water intake port.
	Spark plugs have improper heat range.	Replace the spark plugs (see page 113).
	<ul style="list-style-type: none"> <li>• Faulty water pump.</li> <li>• Thermostat clogged.</li> <li>• Faulty thermostat.</li> <li>• Cooling water passage clogged.</li> <li>• Exhaust gas invades cooling system.</li> </ul>	Consult with an authorized Honda outboard motor dealer.
Oil pressure warning system comes on: <ul style="list-style-type: none"> <li>• Oil pressure indicator does not come on.</li> <li>• Oil pressure warning buzzer sounds.</li> <li>• Engine speed decreases.</li> <li>• Engine speed cannot be increased by opening the throttle.</li> </ul>	Shortage of engine oil	Add engine oil to the specified level (see page 51).
	Improper engine oil is used.	Change the engine oil (see page 111).
PGM-FI warning system comes on: <ul style="list-style-type: none"> <li>• PGM-FI indicator comes on.</li> <li>• PGM-FI warning buzzer sounds intermittently.</li> </ul>	PGM-FI warning system is faulty.	Consult with an authorized Honda outboard motor dealer.
ACG warning system comes on: <ul style="list-style-type: none"> <li>• ACG indicator comes on.</li> <li>• ACG warning buzzer sounds intermittently.</li> </ul>	Battery voltage is too high or low.	Check the battery (see page 115).
	Faulty ACG.	Consult with an authorized Honda outboard motor dealer.

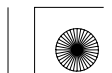



## 16. SPECIFICATIONS

MODEL	BF40D	
Description	BBDJ	
Type	LHD	LHTD
Overall length	794 mm (31.3 in)	
Overall width	372 mm (14.6 in)	
Overall height	1,364 mm (53.7 in)	
Transom height (when Transom angle is 12°)	521 mm (20.5 in)	
Dry mass (weight)*	100 kg (220 lbs)	102 kg (225 lbs)
Rated power	29.4 kW (40 PS)/5,500 min <sup>-1</sup> (rpm)	
Full throttle range	5,000 – 6,000 min <sup>-1</sup> (rpm)	
Engine type	4 stroke OHC in-line 3 cylinder	
Displacement	808 cm <sup>3</sup> (49.3 cu-in)	
Spark plug gap	0.6 – 0.7 mm (0.024 – 0.028 in)	

Starter system	Electric starter
Ignition system	Full transistor battery
Lubrication system	Trochoid pump pressure lubrication
Specified oil	Engine: API standard (SG, SH, SJ) SAE 5W-30 Gear case: API standard (GL-4) SAE 90 Hypoid gear oil
Oil capacity	Engine: Without oil filter replacement 2.0 L (2.1 US qt, 1.8 Imp qt) With oil filter replacement 2.1 L (2.2 US qt, 1.8 Imp qt) Gear case: 0.41 L (0.43 US qt, 0.36 Imp qt)
D.C. output	12 V – 17 A
Cooling system	Water cooling with thermostat
Exhaust system	Water exhaust
Spark plugs	DR7EB (NGK) , X22ESR-UB (DENSO)
Fuel pump	Low pressure side: mechanical type High pressure side: electrical type
Fuel	Unleaded gasoline (91 research octane, 86 pump octane, or higher)
Tank capacity	25 L (6.6 US gal, 5.5 Imp gal)
Gear change	Dog type: Forward – Neutral – Reverse
Steering angle	35° right and left
Trim angle	– 4° to 12° (when Transom angle is 12°)
Tilt up angle	63° (when Transom angle is 12°)
Transom angle	8°, 12°, 16°, 20°, 24°
Remote control steering system	—————

\* Without battery cable, with propeller  
Honda outboards are power rated in accordance with ISO8665 (propeller shaft output).







## SPECIFICATIONS

MODEL	BF40D			
Description Code	BBDJ			
Type	SRTU SRTD SRTZ	LRTU LRTD	LRTL LRTZ	
Overall length	694 mm (27.3 in)			
Overall width	372 mm (14.6 in)			
Overall height	1,258 mm (49.5 in)	1,364 mm (53.7 in)		
Transom height (when Transom angle is 12°)	416 mm (16.4 in)	521 mm (20.5 in)		
Dry mass (weight)*	96 kg (212 lbs)	98 kg (216 lbs)		
Rated power	29.4 kW (40 PS)/5,500 min <sup>-1</sup> (rpm)			
Full throttle range	5,000 – 6,000 min <sup>-1</sup> (rpm)			
Engine type	4 stroke OHC in-line 3 cylinder			
Displacement	808 cm <sup>3</sup> (49.3 cu-in)			
Spark plug gap	0.6 – 0.7 mm (0.024 – 0.028 in)			

Starter system	Electric starter
Ignition system	Full transistor battery
Lubrication system	Trochoid pump pressure lubrication
Specified oil	Engine: API standard (SG, SH, SJ) SAE 5W-30 Gear case: API standard (GL-4) SAE 90 Hypoid gear oil
Oil capacity	Engine: Without oil filter replacement 2.0 L (2.1 US qt, 1.8 Imp qt) With oil filter replacement 2.1 L (2.2 US qt, 1.8 Imp qt) Gear case: 0.41 L (0.43 US qt, 0.36 Imp qt)
D.C. output	12 V – 17 A
Cooling system	Water cooling with thermostat
Exhaust system	Water exhaust
Spark plugs	DR7EB (NGK) , X22ESR-UB (DENSO)
Fuel pump	Low pressure side: mechanical type High pressure side: electrical type
Fuel	Unleaded gasoline (91 research octane, 86 pump octane, or higher)
Tank capacity	25 L (6.6 US gal, 5.5 Imp gal)
Gear change	Dog type: Forward – Neutral – Reverse
Steering angle	35° right and left
Trim angle	– 4° to 12° (when Transom angle is 12°)
Tilt up angle	63° (when Transom angle is 12°)
Transom angle	8°, 12°, 16°, 20°, 24°
Remote control steering system	Motor-mounted

\* Without battery cable, with propeller  
Honda outboards are power rated in accordance with ISO8665 (propeller shaft output).





## SPECIFICATIONS

MODEL	BF50D	
Description Code	BBEJ	
Type	LHD	LHTD
Overall length	794 mm (31.3 in)	
Overall width	372 mm (14.6 in)	
Overall height	1,364 mm (53.7 in)	
Transom height (when Transom angle is 12°)	521 mm (20.5 in)	
Dry mass (weight)*	100 kg (220 lbs)	102 kg (225 lbs)
Rated power	36.8 kW (50 PS)/5,750 min <sup>-1</sup> (rpm)	
Full throttle range	5,500 – 6,000 min <sup>-1</sup> (rpm)	
Engine type	4 stroke OHC in-line 3 cylinder	
Displacement	808 cm <sup>3</sup> (49.3 cu-in)	
Spark plug gap	0.6 – 0.7 mm (0.024 – 0.028 in)	

Starter system	Electric starter
Ignition system	Full transistor battery
Lubrication system	Trochoid pump pressure lubrication
Specified oil	Engine: API standard (SG, SH, SJ) SAE 5W-30 Gear case: API standard (GL-4) SAE 90 Hypoid gear oil
Oil capacity	Engine: Without oil filter replacement 2.0 L (2.1 US qt, 1.8 Imp qt) With oil filter replacement 2.1 L (2.2 US qt, 1.8 Imp qt) Gear case: 0.41 L (0.43 US qt, 0.36 Imp qt)
D.C. output	12 V – 17 A
Cooling system	Water cooling with thermostat
Exhaust system	Water exhaust
Spark plugs	DR7EB (NGK) , X22ESR-UB (DENSO)
Fuel pump	Low pressure side: mechanical type High pressure side: electrical type
Fuel	Unleaded gasoline (91 research octane, 86 pump octane, or higher)
Tank capacity	25 L (6.6 US gal, 5.5 Imp gal)
Gear change	Dog type: Forward – Neutral – Reverse
Steering angle	35° right and left
Trim angle	– 4° to 12° (when Transom angle is 12°)
Tilt up angle	63° (when Transom angle is 12°)
Transom angle	8°, 12°, 16°, 20°, 24°
Remote control steering system	—————

\* Without battery cable, with propeller  
Honda outboards are power rated in accordance with ISO8665 (propeller shaft output).





## SPECIFICATIONS

MODEL	BF50D			
Description Code	BBEJ			
Type	SRTU SRTD SRTZ	LRD	LRTU LRTD	LRTL LRTZ
Overall length	694 mm (27.3 in)			
Overall width	372 mm (14.6 in)			
Overall height	1,258 mm (49.5 in)	1,364 mm (53.7 in)		
Transom height (when Transom angle is 12°)	416 mm (16.4 in)	521 mm (20.5 in)		
Dry mass (weight)*	96 kg (212 lbs)		98 kg (216 lbs)	
Rated power	36.8 kW (50 PS)/5,750 min <sup>-1</sup> (rpm)			
Full throttle range	5,500 – 6,000 min <sup>-1</sup> (rpm)			
Engine type	4 stroke OHC in-line 3 cylinder			
Displacement	808 cm <sup>3</sup> (49.3 cu-in)			
Spark plug gap	0.6 – 0.7 mm (0.024 – 0.028 in)			

Starter system	Electric starter
Ignition system	Full transistor battery
Lubrication system	Trochoid pump pressure lubrication
Specified oil	Engine: API standard (SG, SH, SJ) SAE 5W-30 Gear case: API standard (GL-4) SAE 90 Hypoid gear oil
Oil capacity	Engine: Without oil filter replacement 2.0 L (2.1 US qt, 1.8 Imp qt) With oil filter replacement 2.1 L (2.2 US qt, 1.8 Imp qt) Gear case: 0.41 L (0.43 US qt, 0.36 Imp qt)
D.C. output	12 V – 17 A
Cooling system	Water cooling with thermostat
Exhaust system	Water exhaust
Spark plugs	DR7EB (NGK) , X22ESR-UB (DENSO)
Fuel pump	Low pressure side: mechanical type High pressure side: electrical type
Fuel	Unleaded gasoline (91 research octane, 86 pump octane, or higher)
Tank capacity	25 L (6.6 US gal, 5.5 Imp gal)
Gear change	Dog type: Forward – Neutral – Reverse
Steering angle	35° right and left
Trim angle	– 4° to 12° (when Transom angle is 12°)
Tilt up angle	63° (when Transom angle is 12°)
Transom angle	8°, 12°, 16°, 20°, 24°
Remote control steering system	Motor-mounted

\* Without battery cable, with propeller  
Honda outboards are power rated in accordance with ISO8665 (propeller shaft output).





## SPECIFICATIONS

MODEL	BF50D				
Description Code	BBEJ				
Type	YHD	XHD	YHTD	YRTD	XRTD XRTL
Overall length	794 mm (31.3 in)			694 mm (27.3 in)	
Overall width	372 mm (14.6 in)				
Overall height	1,399 mm (55.1 in)	1,465 mm (57.7 in)	1,399 mm (55.1 in)	1,465 mm (57.7 in)	
Transom height (when Transom angle is 12°)	556 mm (21.9 in)	622 mm (24.5 in)	556 mm (21.9 in)	622 mm (24.5 in)	
Dry mass (weight)*	101 kg (223 lbs)	104 kg (229 lbs)	103 kg (227 lbs)	99 kg (218 lbs)	102 kg (225 lbs)
Rated power	36.8 kW (50 PS)/5,750 min <sup>-1</sup> (rpm)				
Full throttle range	5,500 – 6,000 min <sup>-1</sup> (rpm)				
Engine type	4 stroke OHC in-line 3 cylinder				
Displacement	808 cm <sup>3</sup> (49.3 cu-in)				
Spark plug gap	0.6 – 0.7 mm (0.024 – 0.028 in)				

Starter system	Electric starter
Ignition system	Full transistor battery
Lubrication system	Trochoid pump pressure lubrication
Specified oil	Engine: API standard (SG, SH, SJ) SAE 5W-30 Gear case: API standard (GL-4) SAE 90 Hypoid gear oil
Oil capacity	Engine: Without oil filter replacement 2.0 L (2.1 US qt, 1.8 Imp qt) With oil filter replacement 2.1 L (2.2 US qt, 1.8 Imp qt) Gear case: 0.41 L (0.43 US qt, 0.36 Imp qt)
D.C. output	12 V – 17 A
Cooling system	Water cooling with thermostat
Exhaust system	Water exhaust
Spark plugs	DR7EB (NGK) , X22ESR-UB (DENSO)
Fuel pump	Low pressure side: mechanical type High pressure side: electrical type
Fuel	Unleaded gasoline (91 research octane, 86 pump octane, or higher)
Tank capacity	25 L (6.6 US gal, 5.5 Imp gal)
Gear change	Dog type: Forward – Neutral – Reverse
Steering angle	35° right and left
Trim angle	– 4° to 12° (when Transom angle is 12°)
Tilt up angle	63° (when Transom angle is 12°)
Transom angle	8°, 12°, 16°, 20°, 24°
Remote control steering system	Motor-mounted

\* Without battery cable, with propeller  
Honda outboards are power rated in accordance with ISO8665 (propeller shaft output).





## SPECIFICATIONS

### Noise and Vibration

MODEL	BF40D		BF50D	
CONTROL SYSTEM	T (Tiller handle)	R (Remote control)	T (Tiller handle)	R (Remote control)
Sound Pressure level at operator's ears (2006/42/EC, ICOMIA 39-94)	86 dB (A)	79 dB (A)	87 dB (A)	80 dB (A)
Uncertainty	3 dB (A)	2 dB (A)	3 dB (A)	2 dB (A)
Measured sound power level (Reference to EN ISO3744)	93 dB (A)	_____	95 dB (A)	_____
Uncertainty	3 dB (A)	_____	3 dB (A)	_____
Vibration level at hand arm (2006/42/EC, ICOMIA 38-94)	3.0 m/s <sup>2</sup>	Not exceed 2.5 m/s <sup>2</sup>	3.3 m/s <sup>2</sup>	Not exceed 2.5 m/s <sup>2</sup>
Uncertainty	0.8 m/s <sup>2</sup>	_____	0.8 m/s <sup>2</sup>	_____

Reference to: ICOMIA Standard: as it specifies the engine operating conditions and measurement conditions.





## 17. MAJOR Honda DISTRIBUTOR ADDRESSES

For further information, please contact Honda Customer Information Centre at the following address or telephone number:

### For European

#### AUSTRIA

**Honda Motor Europe (North)**  
Hondastraße 1  
2351 Wiener Neudorf  
Tel. : +43 (0)2236 690 0  
Fax : +43 (0)2236 690 480  
<http://www.honda.at>

#### BALTIC STATES (Estonia/Latvia/ Lithuania)

**Honda Motor Europe Ltd.**  
Estonian Branch  
Tulika 15/17  
10613 Tallinn  
Tel. : +372 6801 300  
Fax : +372 6801 301  
✉ [honda.baltic@honda-eu.com](mailto:honda.baltic@honda-eu.com).

#### BELGIUM

**Honda Motor Europe (North)**  
Doornveld 180-184  
1731 Zellik  
Tel. : +32 2620 10 00  
Fax : +32 2620 10 01  
<http://www.honda.be>  
✉ [BH\\_PE@HONDA-EU.COM](mailto:BH_PE@HONDA-EU.COM)

#### BULGARIA

**Kirov Ltd.**  
49 Tsaritsa Yoana Blvd  
1324 Sofia  
Tel. : +359 2 93 30 892  
Fax : +359 2 93 30 814  
<http://www.kirov.net>  
✉ [honda@kirov.net](mailto:honda@kirov.net)

#### CROATIA

**Fred Bobek d.o.o.**  
Honda-Marine Croatia - Trg. - Ind.  
zona bb  
22211 Vodice  
Tel. : +385 22 44 33 00/33 10  
Fax : +385 22 44 05 00  
<http://www.honda-marine.hr>

#### CYPRUS

**Alexander Dimitriou & Sons Ltd.**  
162, Yiannos Kranidiotis  
Avenue  
2235 Latsia, Nicosia  
Tel. : + 357 22 715 300  
Fax : + 357 22 715 400

#### CZECH REPUBLIC

**BG Technik cs, a.s.**  
U Zavodiste 251/8  
15900 Prague 5 - Velka Chuchle  
Tel. : +420 2 838 70 850  
Fax : +420 2 667 111 45  
<http://www.hondamarine.cz>

#### DENMARK

**Tima Products A/S**  
Tårnfalkevej 16  
2650 Hvidovre  
Tel. : +45 36 34 25 50  
Fax : +45 36 77 16 30  
<http://www.tima.dk>

#### FINLAND

**OY Brandt AB**  
Tuupakantie 7B  
01740 Vantaa  
Tel. : +358 207757200  
Fax : +358 (0)9 878 5276  
<http://www.brandt.fi>

#### FRANCE

**Honda Relations Clients**  
TSA 80627  
45146 St Jean de la Ruelle Cedex  
Tel. : 02 38 81 33 90  
Fax : 02 38 81 33 91  
<http://www.honda-fr.com>  
✉ [espaceclient@honda-eu.com](mailto:espaceclient@honda-eu.com)

#### GERMANY

**Honda Motor Europe (North)  
GmbH**  
Sprendlinger Landstraße 166  
63069 Offenbach am Main  
Tel. : +49 69 8309-0  
Fax : +49 69 8320 20  
<http://www.honda.de>  
✉ [info@post.honda.de](mailto:info@post.honda.de)

#### GREECE

**General Automotive Co S.A.**  
71, Leoforos Athinon  
10173 Athens  
Tel. : +30 210 3483582  
Fax : +30 210 3418092  
<http://www.honda.gr>  
✉ [info@saracakis.gr](mailto:info@saracakis.gr)





## MAJOR Honda DISTRIBUTOR ADDRESSES

For further information, please contact Honda Customer Information Centre at the following address or telephone number:

### For European (continued)

#### HUNGARY

**Motor Pedo Co., Ltd.**  
Kamaraerdei ut 3.  
2040 Budaors  
Tel. : +36 23 444 971  
Fax : +36 23 444 972  
<http://www.hondakisgepek.hu>  
✉ [info@hondakisgepek.hu](mailto:info@hondakisgepek.hu)

#### ICELAND

**Bernhard ehf.**  
Vatnagardar 24-26  
104 Reykjavik  
Tel. : +354 520 1100  
Fax : +354 520 1101  
<http://www.honda.is>

#### IRELAND

**Two Wheels ltd**  
M50 Business Park, Ballymount  
Dublin 12  
Tel. : +353 1 4381900  
Fax : +353 1 4607851  
<http://www.hondaireland.ie>  
✉ [Service@hondaireland.ie](mailto:Service@hondaireland.ie)

#### ITALY

**Honda Italia Industriale S.p.A.**  
Via della Cecchignola, 5/7  
00143 Roma  
Tel. : +848 846 632  
Fax : +39 065 4928 400  
<http://www.hondaitalia.com>  
✉ [info.marine@honda-eu.com](mailto:info.marine@honda-eu.com)

#### MALTA

**Associated Motors Company Ltd.**  
New Street in San Gwarkin Road -  
Mriehel Bypass  
Mriehel QRM17  
Tel. : +356 21 498 561  
Fax : +356 21 480 150

#### NETHERLANDS

**Honda Motor Europe (North)**  
Afd. Power Equipment-  
Capronilaan 1  
1119 NN Schiphol-Rijk  
Tel. : +31 (0)20 7070000  
Fax : +31 (0)20 7070001  
<http://www.honda.nl>

#### NORWAY

**AS Kellox**  
Boks 170 - Nygårdsveien 67  
1401 Ski  
Tel. : +47 64 97 61 00  
Fax : +47 64 97 61 92  
<http://www.kellox.no>

#### POLAND

**Aries Power Equipment Sp. z o.o.**  
ul. Wroclawska 25  
01-493 Warszawa  
Tel. : +48 (22) 861 43 01  
Fax : +48 (22) 861 43 02  
<http://www.ariespower.pl>  
<http://www.mojahonda.pl>  
✉ [info@ariespower.pl](mailto:info@ariespower.pl)

#### PORTUGAL

**Honda Portugal S.A.**  
Rua Fontes Pereira de Melo 16  
Abrunheira, 2714-506 Sintra  
Tel. : +351 21 915 53 33  
Fax : +351 21 915 23 54  
<http://www.honda.pt>  
✉ [honda.produtos@honda-eu.com](mailto:honda.produtos@honda-eu.com)

#### REPUBLIC OF BELARUS

**Scanlink Ltd.**  
Kozlova Drive, 9  
220037 Minsk  
Tel. : +375 172 999090  
Fax : +375 172 999900  
<http://www.hondapower.by>

#### RUSSIA

**Honda Motor RUS LLC**  
21. MKAD 47 km., Leninsky district.  
Moscow region, 142784 Russia  
Tel. : +7 (495) 745 20 80  
Fax : +7 (495) 745 20 81  
<http://www.honda.co.ru>  
✉ [postoffice@honda.co.ru](mailto:postoffice@honda.co.ru)

#### SERBIA & MONTENEGRO

**Bazis Grupa d.o.o.**  
Grcica Milenka 39  
11000 Belgrade  
Tel. : +381 11 3820 295  
Fax : +381 11 3820 296  
<http://www.hondasrbija.co.rs>

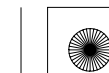



## MAJOR Honda DISTRIBUTOR ADDRESSES

For further information, please contact Honda Customer Information Centre at the following address or telephone number:

### For European (continued)

#### SLOVAK REPUBLIC

**Honda Slovakia, s.r.o.**  
Prievozská 6 821 09 Bratislava  
Tel. : +421 2 32131112  
Fax : +421 2 32131111  
<http://www.honda.sk>

#### SLOVENIA

**AS Domzale Moto Center D.O.O.**  
Blatnica 3A  
1236 Trzin  
Tel. : +386 1 562 22 42  
Fax : +386 1 562 37 05  
<http://www.as-domzale-motoc.si>

#### SPAIN & Las Palmas province (Canary Islands)

**Greens Power Products, S.L.**  
Poligono Industrial Congost -  
Av Ramon Ciurans n°2  
08530 La Garriga - Barcelona  
Tel. : +34 93 860 50 25  
Fax : +34 93 871 81 80  
<http://www.hondaencasa.com>

#### Tenerife province (Canary Islands)

**Automocion Canarias S.A.**  
Carretera General del Sur, KM. 8,8  
38107 Santa Cruz de Tenerife  
Tél. : + 34 (922) 620 617  
Fax : +34 (922) 618 042  
<http://www.aucasa.com>  
✉ [ventas@aucasa.com](mailto:ventas@aucasa.com)  
✉ [taller@aucasa.com](mailto:taller@aucasa.com)

#### SWEDEN

**Honda Nordic AB**  
Box 50583 - Väst kustvägen 17  
20215 Malmö  
Tel. : +46 (0)40 600 23 00  
Fax : +46 (0)40 600 23 19  
<http://www.honda.se>  
✉ [hpesinfo@honda-eu.com](mailto:hpesinfo@honda-eu.com)

#### SWITZERLAND

**Honda Suisse S.A.**  
10 Route des Moulières  
1214 Vernier-Genève  
Tel. : +41 (0)22 939 09 09  
Fax : +41 (0)22 939 09 97  
<http://www.honda.ch>

#### TURKEY

**Anadolu Motor Uretim ve Pazarlama AS**  
Esentepe mah. Anadolu cad. No: 5  
Kartal 34870 Istanbul  
Tel. : +90 216 389 59 60  
Fax : +90 216 353 31 98  
<http://www.anadolumotor.com.tr>  
✉ [antor@antor.com.tr](mailto:antor@antor.com.tr)

#### UKRAINE

**Honda Ukraine LLC**  
101 Volodymyrska Str. - Build. 2  
Kyiv 01033  
Tel. : +380 44 390 14 14  
Fax : +380 44 390 14 10  
<http://www.honda.ua>  
✉ [CR@honda.ua](mailto:CR@honda.ua)

#### UNITED KINGDOM

**Honda (UK) Power Equipment**  
470 London Road  
Slough - Berkshire, SL3 8QY  
Tel. : +44 (0)845 200 8000  
<http://www.honda.co.uk>

### For Australian

#### AUSTRALIA

**Honda Australia Motorcycle and Power Equipment Pty. Ltd**  
1954-1956 Hume Highway  
Campbellfield Victoria 3061  
Tel. : (03) 9270 1111  
Fax : (03) 9270 1133  
<http://www.hondampe.com.au/>

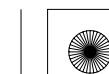





## 18. "EC DECLARATION OF CONFORMITY" CONTENT OUTLINE

### 1) EC-DECLARATION OF CONFORMITY

2) THE UNDERSIGNED, (14), REPRESENTING THE MANUFACTURER, HEREWITH DECLARES THAT THE PRODUCT IS IN CONFORMITY WITH THE PROVISIONS OF THE FOLLOWING EC-DIRECTIVES

2006/42/EC, 2004/108/EC

3) Outboard engine, Propulsion system

4) REFERENCE TO HARMONIZED STANDARDS: EN ISO 8178  
EN ISO 14509

### 5) DESCRIPTION OF THE MACHINERY

6) CATEGORY: 7) Outboard engine

8) MAKE: Honda

9) TYPE:

7)

10) SERIAL NUMBER:

10)

11) MANUFACTURER: Honda Motor Co., Ltd.  
2-1-1 Minamiaoyama Minato-ku Tokyo 107-8556 Japan

12) AUTHORIZED REPRESENTATIVE: Honda Motor Europe Ltd. - Aalst Office  
Wijngaardveld 1 (Noord V), 9300 Aalst, Belgium

13) SIGNATURE:

13)

14) NAME:

14)

17) DATE:

17)

15) TITLE

16)

16)

18) PLACE:

18)





## “EC DECLARATION OF CONFORMITY” CONTENT OUTLINE

<p>1) DECLARATION CE DE CONFORMITE 2) LE SOUSSIGNE, (14), REPRESENTANT DU CONSTRUCTEUR, DÉCLARE PAR LA PRESENTE QUE LE PRODUIT EST CONFORME AUX DISPOSITIONS DES DIRECTIVES CE SUIVANTES</p> <p>3) moteur hors-bord. Système de propulsion</p> <p>4) REFERENCE AUX NORMES HARMONISEES 5) DESCRIPTION DE MACHINE 6) CATEGORIE 7) moteur hors-bord 8) MARQUE</p> <p>9) TYPE 10) NUMERO DI SERIE 11) CONSTRUCTEUR 12) REPRESENTANT HABILITE 13) SIGNATURE 14) NOM 15) TITRE</p> <p>16) Directeur Qualite 17) DATE 18) LIEU</p>	<b>français ( FRENCH )</b>
<p>1) DICHIARAZIONE DI CONFORMITA' CE 2) IL SOTTOSCRITTO, (14), RAPPRESENTANTE DEL COSTRUTTORE, DICHIARA QUI DI SEGUITO CHE IL PRODOTTO E' CONFORME A QUANTO PREVISTO DALLE SEGUENTI DIRETTIVE COMUNITARIE</p> <p>3) MOTORE FUORIBORDO. Sistema di propulsione</p> <p>4) RIFERIMENTO ALLE NORME ARMONIZZATE 5) DESCRIZIONE DELLA MACCHINA 6) CATEGORIA</p> <p>7) MOTORE FUORIBORDO 8) MARCA 9) TIPO 10) NUMERO DI SERIE 11) FABBRICANTE 12) RAPPRESENTANTE AUTORIZZATO</p> <p>13) FIRMA 14) NOME 15) TITOLO 16) DIRETTORE DELLA QUALITA' 17) ADDI 18) LUOGO</p>	<b>italiano ( ITALIAN )</b>
<p>1) EG-KONFORMITÄTSEKLAUNG 2) DER UNTERZEICHNER, (14), DER DEN HERSTELLER VERTRITT, ERKLÄRT HIERMIT, DAB DAS PRODUKT IN ÜBEREINSTIMMUNG MIT DEN BESTIMMUNGEN DER NACHSTEHENDEN EG-RICHTLINIEN IST</p> <p>3) Außenbordmotor. Antriebsart</p> <p>4) VERWEIS AUF HARMONISIERTE NORMEN 5) BESCHREIBUNG DER MASCHINE 6) ART 7) Außenbordmotor</p> <p>8) FABRIKAT 9) TYP 10) SERIEN NUMMER 11) HERSTELLER 12) BEVOLLMÄCHTIGTER 13) UNTERSCHIFT 14) NAME 15) TITEL</p> <p>16) Qualitätssi Cherung 17) DATUM 18) ORT</p>	<b>deutsch ( GERMAN )</b>
<p>1) EG-VERKLARING VAN OVEREENSTEMMING 2) ONDERGETEKENDE, (14), VERTEGENWOORDIGER VAN DE FABRIKANT, VERKLAART HIERMEE DAT HET PRODUCT VOLDOET AAN DE BEPALINGEN VAN DE VOLGENDE EG-RICHTLIJNEN</p> <p>3) buitenboordmotor, Aandrijfsysteem</p> <p>4) REFERENTIE NAAR GEHARMONISEERDE NORMEN 5) BESCHRIJVING VAN DE MACHINE 6) CATEGORIE</p> <p>7) buitenboordmotor 8) FABRIKAT 9) TYPE 10) SERIEN UMMER 11) FABRIKANT 12) GEMACHTIGDE VAN DE FABRIKANT</p> <p>13) HANDTEKENING 14) NAAM 15) TITEL 16) Directeur Kwaliteitszorg 17) DATUM 18) PLAATS</p>	<b>nederlands ( DUTCH )</b>
<p>1) ΕΚ-ΔΗΛΩΣΗ ΕΝΑΡΜΟΝΙΣΗΣ 2) Ο ΥΠΟΓΡΑΦΩΝ, (14), ΕΚΠΡΟΣΩΠΟΝΤΑΣ ΤΟΝ ΚΑΤΑΣΚΕΥΑΣΤΗ, ΔΙΑ ΤΟΥ ΠΑΡΟΝΤΟΣ ΔΗΛΩΝΕΙ ΟΤΙ ΤΟ ΠΡΟΪΟΝ ΒΡΙΣΚΕΤΑΙ ΣΕ ΕΝΑΡΜΟΝΙΣΗ ΜΕ ΤΙΣ ΠΡΟΒΛΕΨΕΙΣ ΤΩΝ ΚΑΤΩΘΙ ΟΔΗΓΙΩΝ ΤΗΣ ΕΕ</p> <p>3) Εξωτερικά μηχανή, Σύστημα Πρόωσης</p> <p>4) ΠΑΡΑΠΟΜΠΗ ΣΤΑ ΕΝΑΡΜΟΝΙΣΜΕΝΑ ΠΡΟΤΥΠΑ 5) ΠΕΡΙΓΡΑΦΗ ΜΗΧΑΝΗΜΑΤΟΣ 6) ΚΑΤΗΓΟΡΙΑ 7) Εξωτερικά μηχανή</p> <p>8) ΕΡΓΟΣΤΑΣΙΟ ΚΑΤΑΣΚΕΥΗΣ 9) ΤΥΠΟΣ 10) ΑΡΙΘΜΟΣ ΣΕΙΡΑΣ 11) ΚΑΤΑΣΚΕΥΑΣΤΗΣ 12) ΕΞΟΥΣΙΟΔΟΤΗΜΕΝΟΣ ΑΝΤΙΠΡΟΣΩΠΟΣ</p> <p>13) ΥΠΟΓΡΑΦΗ 14) ΟΝΟΜΑ 15) ΤΙΤΛΟΣ 16) Υπεύθυνος Ποιότητας 17) ΗΜΕΡΟΜΗΝΙΑ 18) ΤΟΠΟΣ</p>	<b>Ελληνικά ( GREEK )</b>
<p>1) EF OVERENSSTEMMELSEERKLÆRING 2) UNDERTEGNEDE, (14), DER REPRÆSENTERER FABRIKANTEN, ERKLÆRER HERMED AT PRODUKTET ER I OVERENSSTEMMELSE MED BESTEMMELSERNE I FØLGE EF DIREKTIVERNE</p> <p>3) Utenbordsmotor, Fremdrivningssystem</p> <p>4) REFERENCE TIL HARMONISEREDE STANDARDER 5) BESKRIVELSE AF MASKINEN 6) KATEGORI 7) Utenbordsmotor 8) FABRIKANT</p> <p>9) TYPE 10) SERIEN UMMER 11) FABRIKANT 12) FABRIKANTENS REPRÆSENTANT 13) SIGNATURE 14) NAVN 15) TITEL</p> <p>16) Kvalitets Leder 17) DATO 18) STED</p>	<b>dansk ( DANISH )</b>
<p>1) DECLARACIÓN DE CONFORMIDAD 2) EL ABAJO FIRMANTE, (14), EN REPRESENTACIÓN DE FABRICANTE, DECLARA QUE EL PRODUCTO ES CONFORME CON LAS DISPOSICIONES DE LAS SIGUIENTES DIRECTIVAS CE</p> <p>3) Motor fueraborda, Sistema de propulsión</p> <p>4) REFERENCIA A ESTANDARES ARMONIZADOS 5) DESCRIPCIÓN DE LA MAQUINARIA 6) CATEGORÍA 7) Motor fueraborda 8) MARCA</p> <p>9) TIPO 10) NUMERO DE SERIE 11) FABRICANTE 12) REPRESENTANTE AUTORIZADO 13) FIRMA 14) NOMBRE 15) CARGO</p> <p>16) Director de calidad 17) FECHA 18) LUGAR</p>	<b>español ( SPANISH )</b>





## “EC DECLARATION OF CONFORMITY” CONTENT OUTLINE

<p>1) DECLARAÇÃO DE CONFORMIDADE 2) O ABAIXO ASSINADO, (14), EM REPRESENTAÇÃO DO FABRICANTE, PELA PRESENTE DECLARA QUE O PRODUTO ESTÁ EM CONFORMIDADE COM O ESTABELECIDO NAS SEGUINTE DIRECTIVAS COMUNITARIAS 3) Motor fora de borda, Sistema propulsor 4) REFERÊNCIA AS NORMAS HARMONIZADAS 5) DESCRIÇÃO DA MAQUINA 6) CATEGORIA 7) Motor fora de borda 8) MARCA 9) TIPO 10) NUMERO DE SERIE 11) FABRICANTE 12) MANDATARIO AUTORIZADO 13) ASSINATURA 14) NOME 15) TITULO 16) Director de Qualidade 17) DATA 18) LOCAL</p>	<b>português ( PORTUGUESE )</b>
<p>1) EY-VAAITIMUSTENMUKAISUUSVAKUUTUS 2) ALLEKIRJOITANUT, (14), JOKA EDUSTAA VALMISTAJAA, VAKUUTTAA TÄTEN, ETTÄ TUOTE ON SEURAAVIEN EU-DIREKTIIVIEN VAAITIMUSTEN MUKAINEN 3) Peramoottori, Työntöjärjestelmä 4) VITTAUS YHTEISIIN STANDARDEIHIN 5) KUVAUS LAITTEESTA 6) KATEGORIA 7) Peramoottori 8) MERKKI 9) MALLI 10) SARJANUMERO 11) VALMISTAJA 12) VALTUUTETTU EDUSTAJA 13) ALLEKIRJOITUS 14) NIMI 15) TITTELI 16) Laatusääntö 17) PÄIVÄMÄÄRÄ 18) PAIKKA</p>	<b>suomi / suomen kieli ( FINNISH )</b>
<p>1) ЕО-ДЕКЛАРАЦИЯ ЗА СЪОТВЕТСТВИЕ 2) ДОЛУ ПОДПИСАЛИЯТ СЕ, (14), ПРЕДСТАВЛЯВАЩ ДИСТРИБУТОРА, ДЕКЛАРИРА, ЧЕ ПРОДУКТА СЪОТВЕТСТВА НА ИЗСКВАНИЯТА НА СЛЕДНИТЕ ЕВРОПЕЙСКИ ДИРЕКТИВИ 3) ИЗВЪН БОРДОВИ ДВИГАТЕЛ, Задвижваща система 4) СЪОТВЕТСТВИЕ С ХАРМОНИЗИРАНИТЕ СТАНДАРТИ 5) ОПИСАНИЕ НА АРТИКУЛА 6) КАТЕГОРИЯ 7) ИЗВЪНБОРДОВИ ДВИГАТЕЛ 8) МАРКА 9) ТИП 10) СЕРИЕН НОМЕР 11) ПРОИЗВОДИТЕЛ 12) ОТОРИЗИРАН ПРЕСТАВИТЕЛ 13) ПОДПИС 14) ИМЕ 15) ТИТЛА 16) МЕНИДЖЪР НА КАЧЕСТВОТО 17) ДАТА 18) МЯСТО</p>	<b>български ( BULGARIAN )</b>
<p>1) EG-FÖRSÄKRAN OM ÖVERENSSTÄMMELSE 2) UNDERTECKNAD, (14), REPRESENTERANDE TILLVERKARE, FÖRSÄKRAR HÄRMEÐ ATT PRODUKTEN ÖVERENSSTÄMMER MED BESTÄMMELSERNA I FÖLJANDE EG-DIREKTIVE 3) Utomboromotor, Framdrivningssystem 4) REFERERANDE TILL HARMONISERADE STANDARDER 5) BESKRIVNING AV UTRUSTNINGEN 6) KATEGORI 7) Utomboromotor 8) MERKKI 9) TYPBETECKNING 10) SERIENUMER 11) TILLVERKARE 12) REPRESENTERANDE TILLVERKARENS 13) SIGNATUR 14) NAMN 15) TITEL 16) Kvalitetschef 17) DATUM 18) ORT</p>	<b>svenska ( SWEDISH )</b>
<p>1) DEKLARACJA ZGODNOSCI WE 2) NIŻEJ PODPISANY, (14), REPREZENTUJĄCY PRODUCENTA, DEKLARUJE Z CAŁĄ ODPOWIEDZIALNOŚCIĄ, ŻE PRODUKT SPEŁNIA WYMAGANIA ZAWARTE W NASTĘPUJĄCYCH DYREKTYWACH UNIJNYCH 3) Silnik zaburtowy, Układ napędowy 4) ZASTOSOWANE NORMY ZHARMONIZOWANE 5) OPIS URZĄDZENIA 6) KATEGORIA 7) Silnik zaburtowy 8) MARKA 9) TYP 10) NUMERY SERYJNE 11) PRODUCENT 12) UPOWAŻNIONY PRZEDSTAWICIEL PRODUCENTA 13) PODPIS 14) NAZWISKO 15) TYTUŁ 16) Menadżer Jakości 17) DATA 18) MIEJSCE</p>	<b>polski ( POLISH )</b>
<p>1)MEGFELELŐSÉGI NYILATKOZAT 2)ALULÍROTT, (14), MINT A GYÁRTÓ KÉPVISELŐJE NYILATKOZIK, HOGY AZ ALÁBBI TERMÉK MINDENBEN MEGFELEL A KÖVETKEZŐ EC ELOÍRÁSOK RENDELKEZÉSEINEK: 98/37/EC, 89/336/EEC-93/68/EC: 3)KÜLSŐ CSONAKMOTOR, Hajtás rendszer 4)ÖSSZHANGBAN A KÖV. SZABVANYOKKAL 5)A GÉP LEÍRÁSA 6)KATEGÓRIA 7)KÜLSŐ CSONAKMOTOR 8)GYÁRTOTTA 9)TÍPUS 10)SORSZÁM 11)GYÁRTÓ 12)ENGEDELLYEL RENDELKEZŐ KÉPVISELŐ 13)ALÁÍRÁS 14)NÉV 15)BEOSZTAS 16)MINŐSÉGI IGAZGATO 17)KELTEZÉS DATUMA 18)KELTEZÉS HELYE</p>	<b>magyar ( HUNGARIAN )</b>
<p>1) Prohlášení o shodě 2) ZASTUPCE VÝROBCE, (14), SVÝM PODPÍSEM POTVRZUJE, ŽE DANY VÝROBEK JE V SOULADU S NÁSLEDUJÍCÍMI SMĚRNICEMI A NORMAMI EVROPSKEHO SPOLEČENSTVÍ: 3) ZÁVĚSNÝ LODNÍ MOTOR, Pohonný systém 4) ODKAZ NA HARMONIZOVANÉ NORMY: 5) POPIS VÝROBKU 6) KATEGORIE: 7) ZAVĚSNÝ LODNÍ MOTOR 8) ZNAČKA: 9) TYP: 10) VÝROBNÍ ČÍSLO: 11) VÝROBCE: 12) AUTORIZOVANÝ ZASTUPCE: 13) PODPIS: 14) JMENO: 15) POZICE 16) Manažer kvality 17) DATUM: 18) MÍSTO:</p>	<b>čeština ( CZECH )</b>





## “EC DECLARATION OF CONFORMITY” CONTENT OUTLINE

<p>1) ES VYHLÁSENIE O ZHODE 2) DOLUPODPÍSANÝ, (14), ZASTÚPUJÚCI VÝROBCU, TÝMTO DEKLARUJE, ŽE PRODUKT JE V SÚLADE S USTANOVENIAMÍ NASLEDOVNÝCH SMERNÍC ES</p> <p>3) ZÁVESNÝ LODNÝ MOTOR, Systém pohonu</p> <p>4) REFERENCIA K HARMONIZOVANÝM ŠTANDARDOM 5) IDENTIFIKÁCIA STROJOV</p> <p>6) KATEGÓRIA 7) ZÁVESNÝ LODNÝ MOTOR 8) VÝROBCA/ZNAČKA 9) TYP 10) SÉRIOVÉ ČÍSLO</p> <p>11) VÝROBCA 12) AUTORIZOVANÝ ZÁSTUPCA 13) PODPIS 14) MENO 15) POZÍCIA 16) MANAŽÉR KVALITY 17) DÁTUM</p> <p>18) MIESTO</p>	<b>slovenčina (SLOVAK)</b>
<p>1) EF SAMSVARSÆRKLERING 2) UNDERTEGNEDE, (14), SOM REPRÆSENTERER FABRIKANTEN, ERKLÆRER HERVED AT PRODUKTET ER I OVERENSSTEMMELSE MED BESTEMMELSENE I FØLGENDE EU DIREKTIV</p> <p>3) Utenbordsmotor, Fremdrifts system</p> <p>4) REFERANSER TIL HARMONISERED E STANDARDER 5) BESKRIVELSE AV MASKINEN 6) KATEGORI 7) Utenbordsmotor 8) FABRIKANT 9) TYPE 10) SERIE NUMMER 11) FABRIKANT 12) FABRIKANTENS REPRESENTANT 13) SIGNATUR 14) NAVN</p> <p>15) TITTEL 16) Kvalitetssjef 17) DATO 18) STED</p>	<b>norsk (NORWEGIAN)</b>
<p>1) DECLARATIE DE CONFORMITATE. 2) SUBSEMNATUL, (14), REPREZENTAND PE PRODUCATOR, DECLAR PRIN PREZE NTA CA PRODUSUL ESTE IN CONFORMITATE CU PREVEDERILE URMATOARELOR DIRECTIVE CE</p> <p>3) MOTOR IN AFARA BORDULUI (EXTERN), Sistem de propulsie</p> <p>4) REFERIRE LA STANDARDELE ARMONIZATE: 5) DESCRIEREA ECHIPAMENTULUI 6) CATEGORIA: 7) MOTOR EXTERN</p> <p>8) MARCA 9) TIPUL 10) NUMAR DE SERIE 11) PRODUCATOR 12) REPRESENTANT AUTORIZAT 13) SEMNATURA 14) NUME</p> <p>15) TITLUL 16) DIRECTOR DE CALITATE 17) DATA 18) LOCATIE</p>	<b>română (ROMANIAN)</b>
<p>1)EU VASTAVUSDEKLARATSIOON 2)ALLAKIRJUTANU, P. RENNEBOOG, ESINDADES TOOTJAT, DEKLAREERIB SINKOHAL, ET TOODE ON VASTAVUSES JÄRGMISTE EC DIREKTIIVIDE SÄTETEGA</p> <p>3)Pardavāline mootor, Tõukursüsteem</p> <p>4)VIIDE ÜHTLUSTATUD</p> <p>STANDARDITELE: 5)MEHĦANISMI KIRJELDUS 6)KATEGOORIA: 7)pardavāline mootor 8)VALMISTAJA: 9)TÜÜP: 10)SEERIANUMBER:</p> <p>11)TOOTJA: 12)VOLITATUD ESINDAJA: 13)ALLKIRI: 14)NIMI: 15)AMET 16)Kvaliteedijuht 17)KUUPÄEV: 18)KOHT:</p>	<b>estli (ESTONIAN)</b>
<p>1) EK ATBILSTĪBAS DEKLARĀCIJA 2) ZEMĀK MINĒTĀS, (14), KĀ RAŽOTĀJA PĀRSTĀVIS AR ŠO APSTĪPRINA, KĀ ŠIS PRODUKTS PILNĪBĀ ATBILST VĪSIEM STANDARTIEM, KĀS ATRUNĀTI SEKOJOŠAJĀS EC-DIREKTĪVĀS</p> <p>3) Piekarināmais laivas dzinējs, Virzošā spēka sistēma</p> <p>4) Atsaucoties uz saskaņotajiem standartiem 5) Iekārtas apraksts 6) Kategorija 7) Piekarināmais laivas motors</p> <p>8) Preču zīme 9) Tips 10) Sērijas numurs 11) Izgatavotājs 12) Autorizētais pārstāvis 13) Paraksts 14) Vārds, Uzvārds 15) Tituls</p> <p>16) Kvalitātes vadītājs 17) Datums 18) Vieta</p>	<b>latviešu (LATVIAN)</b>
<p>1.EB ATITIKTIES DEKLARACIJA 2.ZEMIAUI PASIRASES, (14), ATSTOVAUJANTIS GAMINTOJA DEKLARUOJA KAD PRODUKTAS ATITINKA REIKALAVIMUS PAGAL ŠIAS EB DIREKTYVAS.</p> <p>3. PAKABINAMAS VARIKLIS, Varomasis būdas</p> <p>4. NUORODA Į HARMONIZUOTUS STANDARTUS. 5. MAŠINOS APRAŠYMAS. 6. KATEGORIJA. 7.Pakabinamas variklis. 8. MARKĖ.</p> <p>9. TIPAS 10. SERIJINIS NUMERIS. 11. GAMINTOJAS. 12. AUTORIZUOTAS ATSTOVAS. 13. PARAŠAS. 14. V. PAVARDĖ</p> <p>15. PAREIGOS 16. KOKYBĖS VADYBININKAS. 17 DATA. 18. VIETA</p>	<b>lietuvių kalba (LITHUANIAN)</b>
<p>1) ES-DEKLARACIJA O USTREZNOSTI 2) PODPISANI, (14), PREDSTAVNIK PROIZVAJALCA, IZJAVLJAM DA IZDELKI USTREZAJO NASLEDNJIM DEKLARACIJAM</p> <p>3) Izvenkrmni motorji, Pogonski sistem</p> <p>4) SKLADNOST Z NASLEDNJIMI STANDARDI 5) OPIS IZDELKOV</p> <p>6) KATEGORIJA 7) Izvenkrmni motorji 8) PROIZVAJA 9) TIP 10) SERIJSKA ŠTEVILKA 11) PROIZVAJALEC 12) POOBLAŠČEN PREDSTAVNIK 13) PODPIS 14) IME 15) FUNKCIJA 16) Direktor presoje 17) DATUM 18 ) KRAJ</p>	<b>slovenščina (SLOVENIAN)</b>





## “EC DECLARATION OF CONFORMITY” CONTENT OUTLINE

1) EB-YFIRLÝSING 2) UNDIRRITAÐUR HR. ,(14), LÝSI YFIR FYRIR HÖND FRAMLEIÐANDA AÐ VARAN UPPFYLLIR EFTIRFARANDI EC-TILSKIPANIR 3) Utanborðsmótorar, knúningsafl kerfi 4) TILVÍSUN UM HEILDARSTAÐAL 5) LÝSING Á VÉLBÚNAÐI 6) FLOKKUR 7) Utanborðsmótorar 8) FRAMLEIÐSLA 9) GERÐ 10) SERÍAL NÚMER 11) FRAMLEIÐANDI 12) LÖGGILDIR AÐILAR 13) UNDIRSKRIFT 14) NAFN 15) TITILL 16) Skráningarstjóri 17) DAGSETNING 18) STAÐUR	<b>Íslenska (ICELANDIC)</b>
1) AT UYGUNLUK BEYANI 2) AŞAĞIDA İMZASI BULUNAN VE İMALATÇININ YETKİLİ TEMSİLCİSİ OLAN ,(14), ÜRÜNÜN ŞU AT YÖNETMELİKLERİNİN HÜKÜMLERİNE UYGUN OLDUĞUNU BEYAN EDER. 3) Dıştan takma motor, tahrik sistemi 4) UYUMLAŞTIRILMIŞ STANDARTLARA ATIF 5) MAKİNANIN TARİFİ 6) KATEGORİ 7) Dıştan takma motor 8) MARKA 9) TİP 10) SERİ NUMARASI 11) İMALATÇI 12) YETKİLİ TEMSİLCİ 13) İMZA 14) ADI 15) ÜNVANI 16) Homologasyon Yöneticisi 17) TARİH 18) YER	<b>Türk (TURKISH)</b>
1)EK-IZJAVA O SUKLADNOSTI 2)POTPISANI P.RENNEBOOG, PREDSTAVNIK PROIZVOĐAČA, IZJAVLJUJE DA JE PROIZVOD U SUKLADNOSTI S ODREDBAMA SLJEDEĆEG EK PROPISA 3)Vanbrodski motor, Pogonski sustav 4)REFERENCA NA USKLAĐENE NORME 5)OPIS STROJA 6)KATEGORIJA 7)Vanbrodski motor 8)IZRADIO 9)TIP 10)SERIJSKI BROJ 11)PROIZVOĐAČ 12)OVLAŠTENI PREDSTAVNIK 13)POTPIS 14)IME 15)TITULA 16)Upravitelj homologacije 17)DATUM 18)MJESTO	<b>hrvatski (CROATIAN)</b>





## 19. INDEX

<b>A</b>		<b>D</b>		Over-rev Limiter..... 95
ACG Indicator/Buzzer		Digital Speedometer ..... 40		PGM-FI Warning System..... 90
Function ..... 34		Digital Tachometer ..... 40		Serial Number ..... 2
Operation ..... 90		Disposal ..... 134		Switch
Anode				H type..... 20
Function ..... 36				R type..... 25
Operation ..... 95		<b>E</b>		
<b>B</b>		“EC DECLARATION OF		<b>F</b>
Battery		CONFORMITY” Content		Frame Serial Number..... 2
Cleaning..... 116		Outline ..... 145		Fast Idle
Connections ..... 46		Emergency Stop		Lever ..... 26
Fluid Level Inspection..... 116		Switch ..... 22, 26		Fuel
Inspection..... 57		Switch Lanyard/Clip..... 22, 27		Filler Cap ..... 38
Storage ..... 132		Switch Spare Clip..... 28, 108		Filter
Break-in Procedure ..... 74		Emission Control System ..... 123		Inspection..... 119
		Engine		Replacement ..... 120
		Cover		Gauge ..... 39
		Fixing Lever ..... 38		Level ..... 52
		Removal/Installation ..... 50		Line
		Oil		Connection..... 59
		Change ..... 111		Connector..... 39
		Level Inspection ..... 51		Disconnection ..... 100
		Refilling..... 51		Priming ..... 60
		Protection System ..... 90		Storage ..... 129
		ACG Warning System..... 90		Tank Cleaning..... 122
		Anodes ..... 95		Tank Filter ..... 122
		Oil Pressure Warning		Fuse..... 124
		System ..... 90		
		Overheat Warning System..... 90		





# INDEX

## G

- Gasoline Containing Alcohol ..... 53
- Gear
  - Shifting ..... 75, 81

## I

- Installation
  - Outboard Motor ..... 43
  - Height ..... 42
  - Location ..... 42
- Interface Coupler ..... 40

## L

- Lubrication..... 118

## M

- Maintenance..... 107
- Maintenance Schedule..... 109
- Major Honda Distributor
  - Addresses ..... 142
- Manual
  - Relief Valve
    - Function ..... 31
    - Operation ..... 88
- Moorage ..... 87

## N

- Neutral Release Lever..... 25

## O

- Oil Pressure Indicator/Buzzer
  - Function ..... 33
  - Operation ..... 90
- Operation ..... 74
- Outboard Motor
  - Angle Inspection..... 44
  - Installation ..... 43
  - Storage Position..... 133
- Over-rev Limiter ..... 95
- Overheat Indicator/Buzzer
  - Function ..... 34
  - Operation ..... 90

## P

- PGM-FI Indicator/Buzzer
  - Function ..... 35
  - Operation ..... 90
- Power Tilt Switch
  - Function ..... 30
  - Operation ..... 88
- Power Trim/Tilt Switch
  - Function ..... 29
- Pre-operation Checks..... 50
  - Battery..... 57

- Engine Oil..... 51
- Fuel ..... 52
- Fuel Filter..... 56
- Other Checks ..... 58
- Propeller and Cotter Pin
  - Inspection..... 54
- Remote Control Lever
  - Friction..... 56
- Steering Handle Friction..... 56
- Tiller Handle Height/Angle
  - Adjustment..... 55
- Propeller
  - Inspection..... 54
  - Replacement ..... 125
  - Selection ..... 49





# INDEX

## R

- Remote Control
  - Box
    - Identification ..... 17
    - Installation Location ..... 48
  - Cable Length..... 49
  - Installation ..... 48
  - Lever
    - Function ..... 24
    - Friction Adjustment..... 56

## S

- Safety
  - Carbon Monoxide Poisoning
    - Hazard..... 10
  - Fire and Burn Hazards..... 10
  - Information ..... 8
  - Label Locations ..... 11
  - Operator Responsibility ..... 8
  - Shallow Water Operation ..... 96
  - Shift Lever ..... 20
  - Spare Clip, Emergency Stop
    - Switch ..... 23, 28
  - Spark Plugs ..... 113
  - Specifications ..... 136
  - Starting the Engine
    - Emergency Starting ..... 68
    - H Type ..... 61

152

- R Type ..... 65
- Steering ..... 76
- Steering Handle Friction..... 56
  - Function ..... 23
  - Operation ..... 76
- Stopping the Engine
  - Emergency ..... 97
  - Normal Stop
    - H Type ..... 98
    - R Type ..... 99
- Storage ..... 129
- Submerged Outboard Motor
  - Servicing ..... 127
- T
  - Tachometer ..... 39
  - Throttle Friction
    - Adjuster..... 21
  - Throttle Grip ..... 21
  - Tiller Handle ..... 15
  - Tiller Handle Height/Angle
    - Adjustment..... 55
  - Tilt Lever ..... 32
  - Tilt Lock Lever ..... 33
  - Tilting the Outboard Motor ..... 85
  - Tool Kit and Emergency
    - Parts ..... 58, 108
  - Trailering ..... 103

- Transom
  - Angle Adjusting Rod..... 32
  - Height ..... 41
- Transporting..... 100
- Trim Meter
  - Function ..... 30
  - Operation ..... 84
- Trim Tab
  - Function ..... 36
  - Adjustment..... 89
- Trimming the Outboard Motor..... 79
- Troubleshooting
  - Warning System
    - Comes On ..... 135

## V

- Vapor Separator Draining..... 130

## W

- Wiring Diagram..... 153
  - Inside back cover







## WIRING DIAGRAM

### CONTENTS

TILLER HANDLE TYPE ..... W1  
 SIDE-MOUNT REMOTE  
 CONTROL TYPE  
 (For Analogue Meter) ..... W2  
 SIDE-MOUNT REMOTE  
 CONTROL TYPE  
 (For Digital Meter) ..... W3  
 PANEL-MOUNT/TOP-MOUNT  
 REMOTE CONTROL TYPE  
 (For Analogue Meter) ..... W4  
 PANEL-MOUNT/TOP-MOUNT  
 REMOTE CONTROL TYPE  
 (For Digital Meter) ..... W5

### ABBREVIATIONS

Symbol	Part name
ALT	ALTERNATOR
Bat	BATTERY
Bl (W-L)	BLACK (WHITE LINE)
Bz	BUZZER
ComC	COMMUNICATION COUPLER
CKPSe 1	CKP SENSOR 1
CKPSe 2	CKP SENSOR 2
CoPa	CONTROL PANEL

DgSpMe	DIGITAL SPEEDOMETER
DgTme	DIGITAL TACHOMETER
DLC	DATA LINK CONNECTOR
ECTSe	ECT SENSOR
EBTSe	EBT SENSOR
EmSw	EMERGENCY STOP SWITCH
EOPSw	ENGINE OIL PRESSURE SWITCH
F In 1	No.1 FUEL INJECTOR
F In 2	No.2 FUEL INJECTOR
F In 3	No.3 FUEL INJECTOR
FP	FUEL PUMP
FReSe	FUEL RESERVE SENSOR
Fu	FUSE
FuBx	FUSE BOX
GND	GROUND
HO2Se	HEATED OXYGEN SENSOR
HrMe	HOUR METER
IACV	IAC VALVE
IATSe	IAT SENSOR
IfC	INTERFACE COUPLER
IgC 1	No.1 IGNITION COIL

IgC 2	No.2 IGNITION COIL
IgC 3	No.3 IGNITION COIL
IgSw	ENGINE SWITCH
IND	INDICATOR
JC 1	JOINT CONNECTOR 1
JC 2	JOINT CONNECTOR 2
MaRL	MAIN RELAY
MAPSe	MAP SENSOR
NSw	NEUTRAL SWITCH
PL	INDICATOR LAMP (PT/TTO) (POWER TRIM/TILT TYPE ONLY)
PT/TMo	POWER TRIM/TILT MOTOR
PT/TRL	POWER TRIM/TILT RELAY
PT/TSw	POWER TRIM/TILT SWITCH
PTiSw	POWER TILT SWITCH
PuC	PULSER COIL
PuRo	PULSER ROTOR
RCBx	REMOTE CONTROL BOX
(RCTO)	REMOTE CONTROL TYPE ONLY





## WIRING DIAGRAM

Re/Re	REGULATOR/ RECTIFIER
SHLD	SHIELD
SpMe	SPEEDOMETER
SP 1	No.1 SPARK PLUG
SP 2	No.2 SPARK PLUG
SP 3	No.3 SPARK PLUG
StMo	STARTER MOTOR
StSol	STARTER SOLENOID
TASe	TA SENSOR
TEse	TE SENSOR
TH	TILLER HANDLE
Tme	TACHOMETER
TPSe	TP SENSOR
TrASe	TRIM ANGLE SENSOR
TrMe	TRIM METER
VMe	VOLTMETER

### WIRE COLOR CODE

Bl	BLACK
Br	BROWN
Bu	BLUE
G	GREEN
Gr	GRAY
Lb	LIGHT BLUE
Lg	LIGHT GREEN
Na	NATURAL
O	ORANGE
P	PINK
R	RED
W	WHITE
Y	YELLOW

### SWITCH CONNECTIONS

#### IGNITION SWITCH

	E	IG	BAT	LOAD	ST
COLOR	Bl	Bl/R	W/Bl	Bl/Y	Bl/W
OFF	○—○				
ON			○—○		
START			○—○	○—○	

#### POWER TRIM/TILT SWITCH

	Lg	W/Bl	Lb
UP	○—○		
NORMAL			
DOWN		○—○	

#### EMERGENCY STOP SWITCH

	Bl/R	Bl
PUSH or REMOVE SWITCH CLIP	○—○	○—○
SWITCH CLIP SET		

#### NEUTRAL SWITCH

	Bl/Bu	Bl
NEUTRAL	○—○	○—○
GEAR IN		

#### POWER TILT SWITCH

	Lg	W/Bl	Lb
UP	○—○	○—○	
NORMAL			
DOWN		○—○	○—○

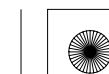



11/09/05 19:30:22 32ZZ4620\_155

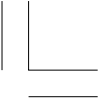

---

**MEMO**

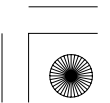
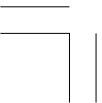



11/09/05 19:30:24 32ZZ4620\_156

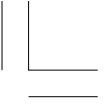

---

**MEMO**



**156**

